

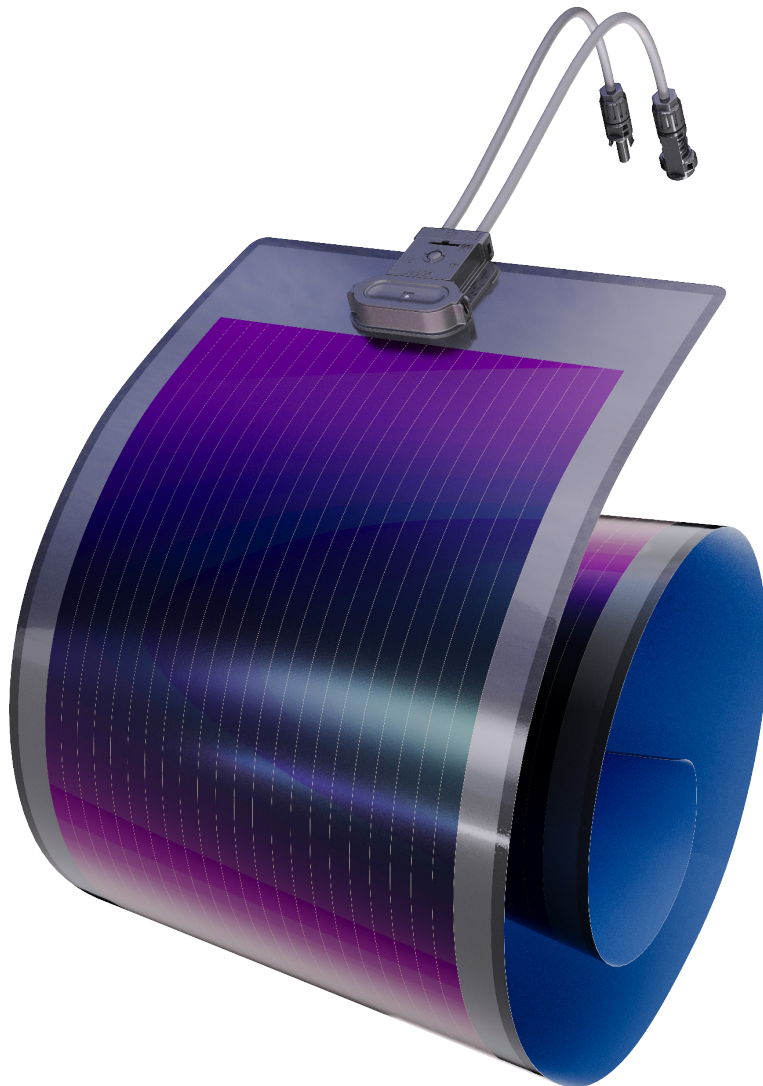

USER GUIDE

HELIKIT



Contact Information:

Please visit our website at www.igepa.de/solar or contact us directly:

IGEPA group GmbH & Co. KG
Heidenkampsweg 74-76
D-20097 Hamburg
Germany
Tel: +49 (0) 40 7277880
Email: solar@igepagroup.com

Publishing Information:

IGEPA group GmbH & Co. KG
Heidenkampsweg 74-76
D-20097 Hamburg
Germany

Document Title: HeliaKit_User Guide_EN | REV: 1

Release: February 2025

Copyright Heliatek GmbH. Heliatek® and HeliaSol® are registered trademarks of Heliatek GmbH.

CAUTION

Please read this user guide thoroughly before use and act accordingly. Always keep this user guide for future reference. Deviating from the recommended steps can pose risks to life, health, and property for you or others. The risks mentioned in this user guide are not exhaustive and do not replace careful and cautious handling of the product. The warranty conditions will be void if the instructions in this user guide are not strictly followed. Always comply with your local regulations. IGEPA Group assumes no liability for damage caused by improper use, incorrect assembly, operation, maintenance, disassembly, or disposal. In case of doubt, always seek the approval of IGEPA Group first. If you have any questions or problems understanding any part of the user guide, please contact us before proceeding with your actions.

Our contact information can be found in this document and on our website: www.igepa.de/solar

TABLE OF CONTENTS

1 GENERAL INFORMATION	4
2 SAFETY INSTRUCTIONS	5
2.1 SAFETY INSTRUCTIONS	5
2.2 SYMBOL KEY	6
3 SCOPE OF DELIVERY	7
4 ASSEMBLY INSTRUCTIONS	8
4.1 AREAS OF APPLICATION	8
4.2 SHADING	9
4.3 INSTALLATION LOCATION	10
4.4 SUBSTRATE PREPARATION	12
4.5 INSTALLATION	13
4.6 WIRING	23
4.7 INITIAL OPERATION	24
4.8 SYSTEM REGISTRATION	25
5 MAINTENANCE	25
5.1 SYSTEM INSPECTION	25
5.2 CLEANING	26
6 DISASSEMBLY AND DISPOSAL	28
6.1 DISASSEMBLY	28
6.2 DISPOSAL	29
7 CERTIFICATES & DATA SHEETS	29
APPENDIX 1: CHECKLIST FOR HELIASOL INSTALLATION	30

1 GENERAL INFORMATION

The Heliakit is a fully ready-to-use prepackage solar power kit by Heliatek in collaboration with IGEPA, designed for easy solar power generation by the customer. The kit consists of 16 HeliSol solar modules, a micro-inverter, the necessary connection cables, and a mounting roller.

This user guide provides you with all the information needed for the proper and safe handling of the Heliakit. In the following chapters, you will find all the necessary information about safety, storage, installation, operation, maintenance, disassembly, and disposal of the kit. Please ensure that this user guide is accessible and, in the event of a change of owner or user, is passed on to the person responsible for the operation of the system.

HeliSol is an innovative organic solar film for generating electrical energy from sunlight, developed and tested according to IEC 61730:2016 Class II, for an ambient temperature range of -40 °C to 85 °C. It is a ready-to-install product, already equipped with a junction box and connectors on the front, and an integrated back adhesive for quick and easy installation. From here on, HeliSol refers to the solar film and describes the entire product.

This user guide does not describe the applicable guidelines for the planning, approval, installation, and operation of photovoltaic systems. Ensure that you comply with all relevant local and national laws, regulations, and standards during installation, wiring, operation, maintenance, and disposal of the solar films. Please read the user guide carefully and follow each step as described to avoid damage to the solar films and prevent any risk of injury to persons. Also, please read all other applicable documents, such as the datasheet and warranty terms.

CAUTION

The warranty conditions will be void if the instructions in this document are not strictly followed. Heliatek assumes no liability for damages caused by improper use, incorrect assembly, operation, maintenance, disassembly, or disposal.

Read each chapter carefully before performing any step to ensure that you do not overlook any safety instructions. The most important safety instructions can be found in the next section and are also highlighted throughout the entire user guide.

Heliatek is not liable for any actions that are in conflict with those listed in this user guide, including but not limited to improper storage, installation, operation, maintenance, removal, and disposal.

2 SAFETY INSTRUCTIONS

2.1 SAFETY INSTRUCTIONS

HeliaSol 436-2000 generates over 55 V and 1.6 A when exposed to sunlight. Individual solar films may pose an electric shock hazard. Multiple interconnected solar films can present a fatal electric shock hazard in daylight, even with weak lighting. The danger increases with the number of solar films connected in series and/or parallel.

To avoid damage, injuries, fires, or malfunctions of any kind, please observe all safety instructions in the user manual and the following guidelines:

- Do not disconnect the solar films from each other while they are under load.
- Do not disconnect the solar film connectors in daylight unless the solar film is in an open circuit.
- Solar films with damaged cables must be immediately removed from the system.
- Only install the solar films in the application areas described in the assembly instructions section.

CAUTION

Any modification to the solar film will void the warranty and poses the risk of property damage as well as danger to life and limb!

Check if there are any necessary or recommended modifications to your home installation that must be made before installing the Heliakit. If you are unsure, consult a qualified electrician.





Necessary inspections and modifications to the electrical system ("installation") of the building must be carried out exclusively by qualified electrical contractors commissioned by the operator of the electrical system (usually the property owner). In the event of a fire, dry powder or CO₂-based fire extinguishers should be used.

The Heliakit must not obstruct the escape and rescue routes of the building.

Observe the regulations regarding the required minimum distances to neighboring residential units/fire sections in accordance with the building regulations applicable at the intended installation location.

If there is a suspicion that the installation cannot be connected due to the age of the electrical system, it must be checked by a qualified electrician.

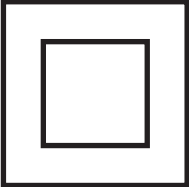
2.2 SYMBOL KEY

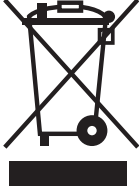
	Caution - Risk of Electric Shock
	Caution - Hot Surface
	Class 2 Protection
	CE Declaration for the individual components
	Do not dispose of in household waste

3 SCOPE OF DELIVERY

The packaging serves to protect the solar films and shield them from external influences during transportation. The dimensions of a packaging carton are (LxWxH) 800 mm x 600 mm x 450 mm. The HeliKit consists of the following components:

- 16x HeliSol 2000-436 AFA solar modules

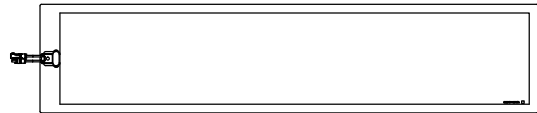

- 1x APSystems EZ1

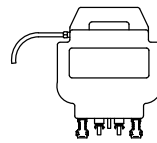

- 2x 8-1 cables – male

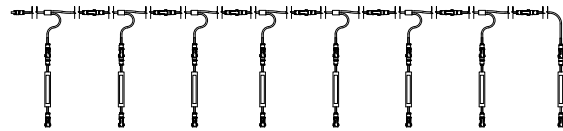

- 2x 8-1 cables – female

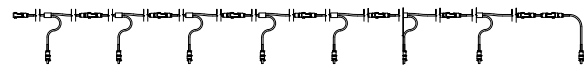

- 1x Mounting roll

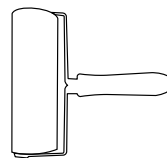

- 1x Tool for removing the protective film

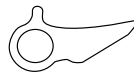

- 1x Tool for opening the connector

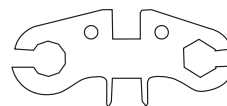

- 2x 10m DC extension cables
(optional: see chapter 4.5)

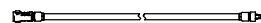

Please check for completeness immediately upon receipt and contact us at solar@igepagroup.com if anything is missing.

4 ASSEMBLY INSTRUCTIONS

4.1 AREAS OF APPLICATION

HeliaSol has an integrated back adhesive ("peel & stick") and can therefore be applied to a variety of materials:

- Glass
- Concrete, fiber cement
- Uncoated aluminum, stainless steel, copper

For the installation of the Heliakit, you will need approximately 20 m² of space. This can be divided into two areas of approximately 10 m² each, corresponding to the respective 8-1 combiner cables. For possible layouts, please refer to the suggestions in section 4.5.

Additionally, you will need the tools provided with the Heliakit, as well as any necessary aids for cleaning the substrate.

The following points must be observed during the installation of the Heliakit.

4.2 SHADING

Shading can cause reverse currents in the solar film, which can impair its performance and, in extreme cases, cause localized burns on the surface of the solar film. To prevent this, it must be ensured that the solar films are never exposed to shading, even temporarily, during the lifetime of the project when selecting the installation location, tilt, and orientation. Keep in mind that shadows depend on the time of day and year and can also be temporarily caused by moving objects. The following information and guidelines will help you assess shading:

- Static objects in the immediate vicinity (up to 10 m) must be avoided.
- Ridges, standing seams, or profiles near the solar film should be avoided.
- Moving objects in the immediate vicinity (up to 10 m), such as people, vehicles, or cleaning equipment, must be avoided.
- Diffuse shadowing from objects more than 10 m away presents only a low risk of damage but should still be avoided.

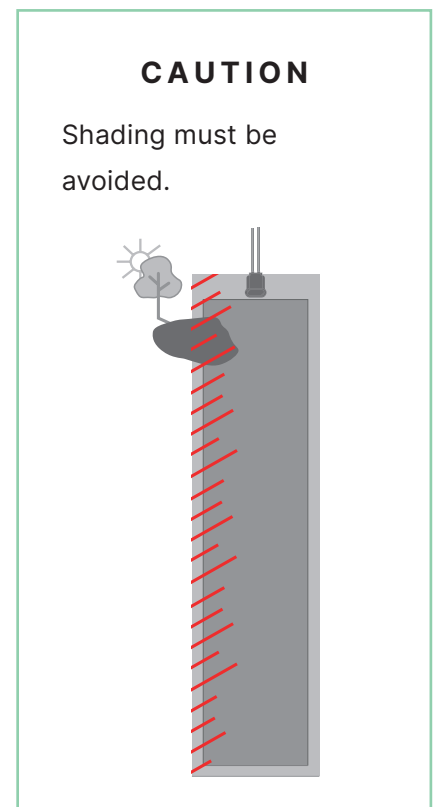

CAUTION

Concentrating sunlight onto the surface of the solar film using mirrors or other means is not permitted. It must be ensured that building components or technical equipment nearby do not cause such side effects on the solar film.

Do not place objects on the solar film, such as tools or cleaning equipment. Clean stains, such as bird droppings, when performing maintenance tasks.

4.3 INSTALLATION LOCATION

HeliaSol has an expected lifespan of 20 years for power generation. Please ensure that the substrate of the mounting roof has a remaining lifespan of at least 20 years. Additionally, the substrate must be able to withstand the forces involved during the installation of HeliaSol and must not crack or break during this process.

The installation is only permitted outdoors.

HeliaSol can be installed in wind and snow load zones of level 1.

HeliaSol can be installed at altitudes up to 2000 meters.

For facade installations, the installation height must be at least 2.5 meters above the ground. For roof installations, mounting is only allowed on areas that are not freely accessible.

HeliaSol must not be installed on movable objects, such as vehicles. Installation in marine environments or in highly corrosive environments is also not permitted.

The back adhesive of HeliaSol is qualified for a firm, permanent bond. The mounting surface must be clean and dry—free from dirt, moisture, dust, oil, grease, adhesives, or other contaminants that could prevent or impair the firm adhesion of the solar film to the mounting surface. If the mounting surface is dirty, clean it with material- or surface-specific cleaning agents.

The mounting surface must be flat or curved along an axis with a minimum bending radius of 50 cm. The substrate must always be firm and load-bearing, free from damage, corrosion, or decay, and must be pretreated for bonding according to the mounting instructions (Section 4.4).

CAUTION

Never apply paint, adhesives, or chemicals to the solar film.

HeliaSol must always be installed on substrates with a fixed curvature that is maintained throughout the entire lifespan of the product/project.

The mounting surface where HeliaSol is attached must have a minimum slope of 1° and a maximum slope of 90° (facade) to ensure that water (e.g., rainwater) can drain off the solar film.

Choose the installation location so that HeliaSol is not submerged in water or exposed to water flows. The orientation of the solar film must be chosen so that no rainwater or snowdrifts collect around the junction boxes.

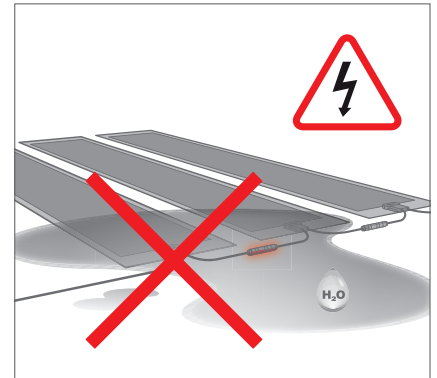
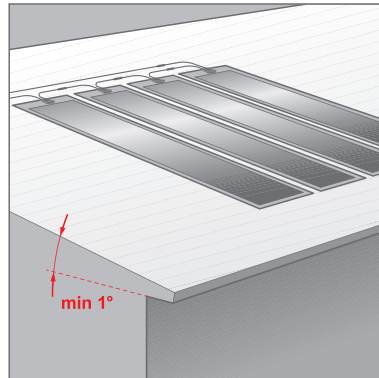
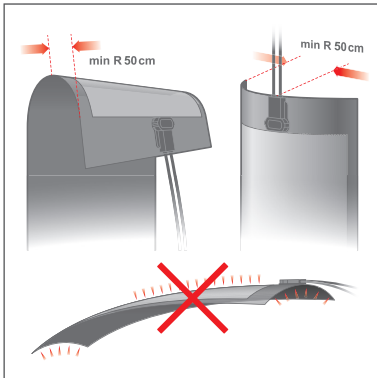

The solar film must be attached to at least 60% of its back adhesive area on the substrate. The long edges must be fully fixed to the substrate.

The module must never be deformed or glued under tension due to raised ridges in the metal or sharp edges like nails or screws.

HeliaSol must not be installed over expansion joints.

HeliaSol must not be installed overlapping or partially covered.

Install the HeliaKit only in the configurations described in this guide.

Do not leave connectors exposed. Do not use any other solar components not included in the kit.

Pay close attention to how the solar films must be connected to the inverter and follow these instructions precisely.

Follow the installation instructions in the inverter's guide.

Always wear insulating gloves and safety shoes (with rubber soles) when working with solar films or system components. Choose your personal protective equipment according to the work and local and/or national regulations. Secure the work area from unauthorized access before starting work. Only use dry, insulated tools.

If, during installation, you notice that a solar film is misaligned compared to the desired position, do not attempt to correct its position. Once the solar film is attached to the mounting surface, correcting the position is not possible without damaging the solar film.

4.4 SUBSTRATE PREPARATION

Sandy substrates (e.g., old plaster facades) or surfaces with paint peeling or corrosion are not suitable for installation. For certain materials with rough surfaces, such as concrete, a primer must be applied before attaching HeliaSol.

Below are the recommended application procedures for installing HeliaSol on glass, acrylic glass, metal, and concrete substrates.

Use of the HeliaKit on glass, acrylic glass, and metal substrates

Ensure that the mounting surface is clean and dry—free from dirt, moisture, dust, oil, grease, adhesives, or other contaminants that could prevent or impair the firm adhesion of the solar film to the mounting surface. If the mounting surface is dirty, clean it with material/surface-specific cleaning agents.

Use of the HeliaKit on concrete substrates

When using HeliaSol on concrete, in addition to the cleaning described in the previous section, a primer must be applied.

Below are the recommended primers and their application procedures for installing HeliaSol on bitumen and concrete substrates. For further information or assistance, please contact the IGEPA Group at solar@igepagroup.com.

Substrate Material	Concrete	
Primer	Tesa 60153	3M Primer 94
Type	Liquid	
Preparation	Ready to use	
Application	Apply primer with a brush	
Drying Time	1-5 minutes (depending on environmental conditions)	
Amount	50-100 ml/m ² (depending on surface roughness and porosity)	

4.5 INSTALLATION

The modules can be installed on horizontal surfaces with a minimum slope of 1°, up to vertical surfaces with a 90° slope. Installations on facades, parapets, overhead areas, and roof-mounted areas are possible, as long as the substrate preparation guidelines (see section "Substrate Preparation") are followed. Also, observe the instructions from the manufacturer of any cable conduit used for mounting locations.

The weather must be dry, with no rain, snowfall, or strong winds, and the substrate temperature should be above 8°C. Solar films and tools must not be exposed to moisture or rain during installation.

Possible Configurations for Module Arrangement

Depending on available space, there are various options for arranging the modules within a group. The most common layouts are shown in the following diagrams. Other arrangements of the modules are allowed, provided all guidelines in this guide are followed (shading, overlap, wiring, substrate, etc.).

CAUTION

Use only the DC extension pair supplied with the Heliakit. The use of other DC extension cables is not permitted. The Heliakit comes with several pre-assembled cable harnesses. Do not disconnect any connections within these cable harnesses and use the cable harnesses only according to the diagrams below.

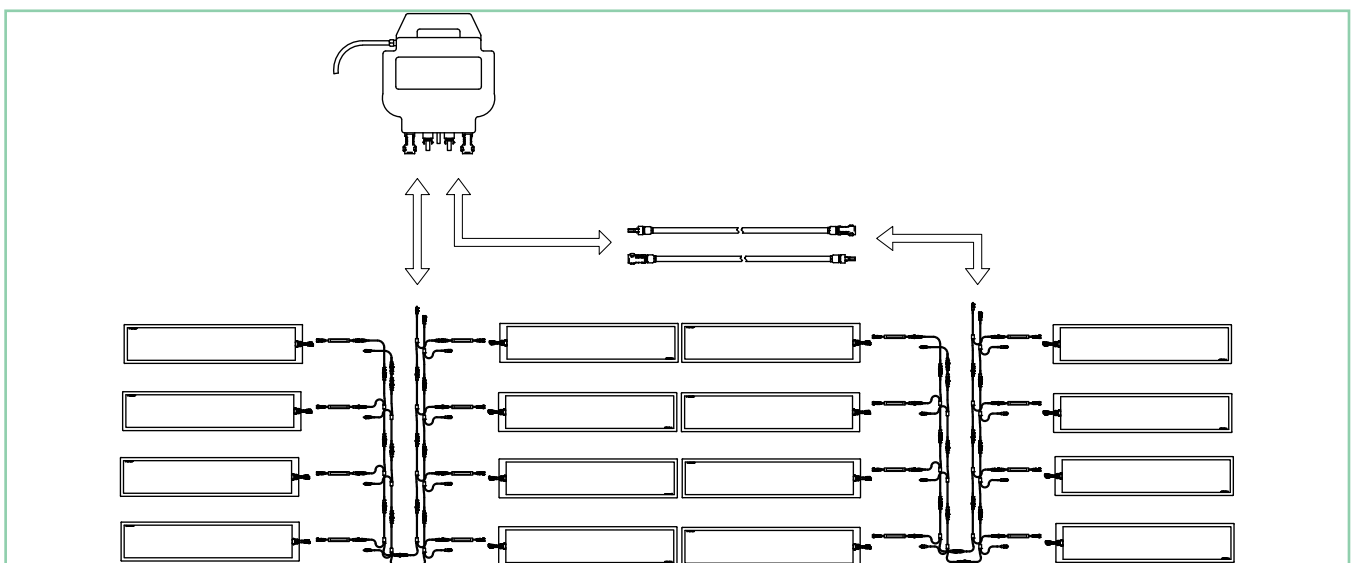

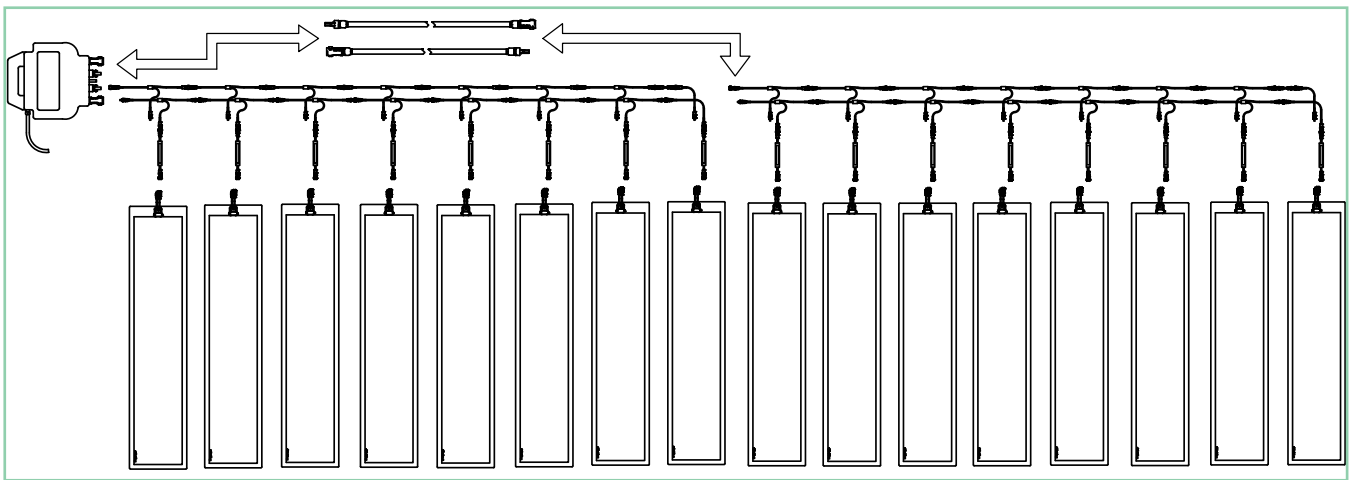
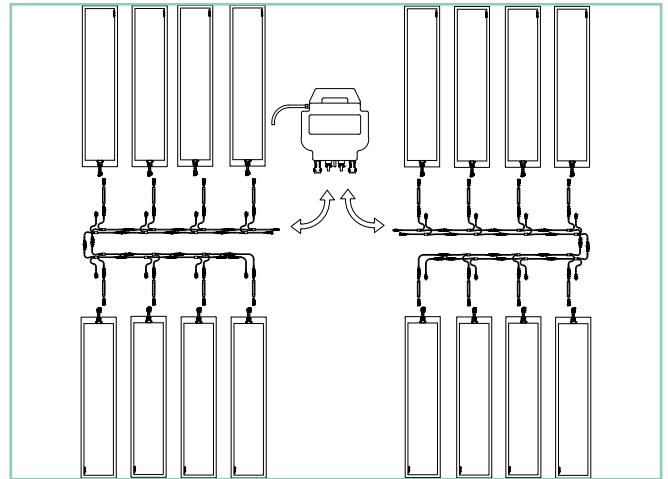
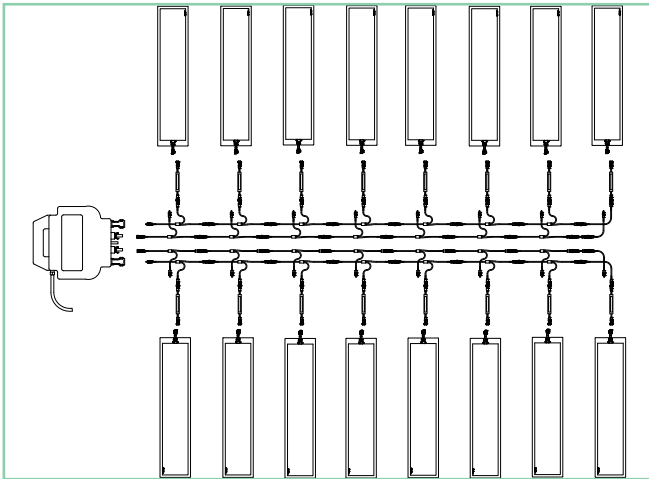

CAUTION

Plan the distance between the module rows and the cable conduit, taking into account the cable lengths. We recommend testing the setup on an open area beforehand, as correcting the position of the modules after they are glued is no longer possible.

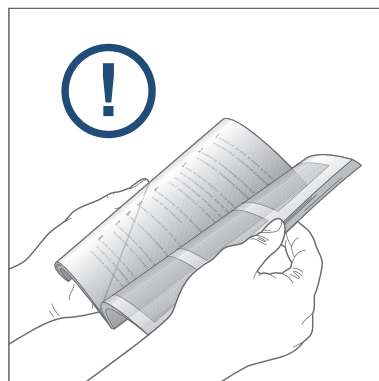
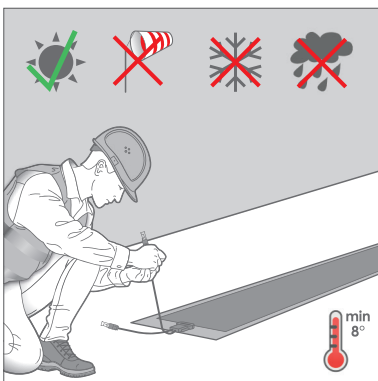

INSTALLATION OF THE CABLE CONDUIT

All cables must be routed and secured in cable conduits, cable protection tubes, or according to local regulations, so that they:

- Do not pose a tripping hazard.
- Are well protected against accidental or intentional damage.
- Are effectively protected against animal bites, as far as this risk is expected at the installation site.
- Are protected from direct sunlight.
- Are protected from standing water.

For this purpose, common cable conduit variants available on the market can be used, such as Niedax 100 × 60 with side holes, but any other conduit is also acceptable, including various colors. Choose the width of the cable conduit based on the selected module configuration (see previous chapter) so that the connection cables are fully accommodated within the conduit and minimum bend radii are maintained. Cable conduits should be installed according to the instructions provided by the respective supplier.

Regardless of the cable conduit used, the cables of the modules should be introduced into the cable conduit from the side. It may be necessary to drill the holes yourself in the cable conduit, with a minimum diameter of 25 mm.

The distance between the module and the cable conduit should be at least 50 mm and a maximum of 380 mm.

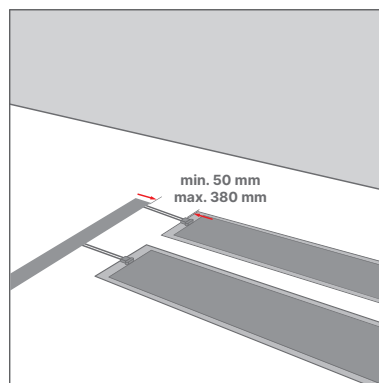
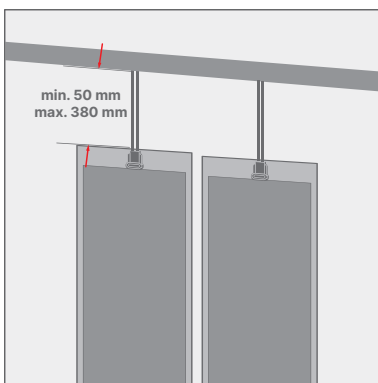

CAUTION

Do not use sharp tools and do not place the solar films face down in direct contact with abrasive surfaces. There is a risk of scratching the surface of the solar film.

Avoid stepping on or walking on the solar film. There is a risk of scratching the surface of the solar film.

The solar film must not be cut, pierced, or mechanically altered.

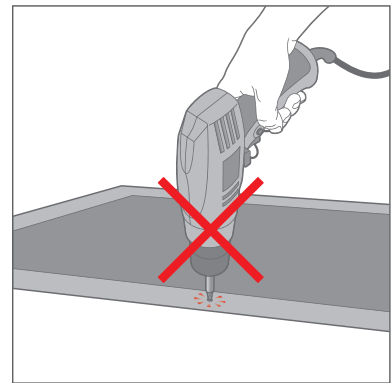
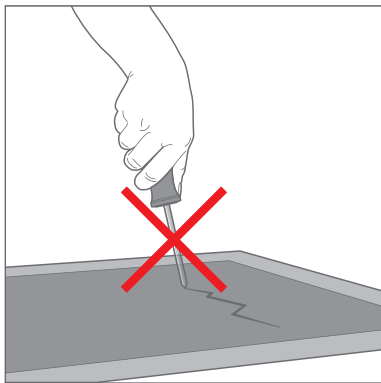

Do not leave objects (e.g., tools, etc.) on the solar film.

Handle the solar film carefully and do not subject it to mechanical stress. Do not hold, carry, or lift the solar film by the junction boxes or cables.

Do not short-circuit the solar films by connecting their terminals together.

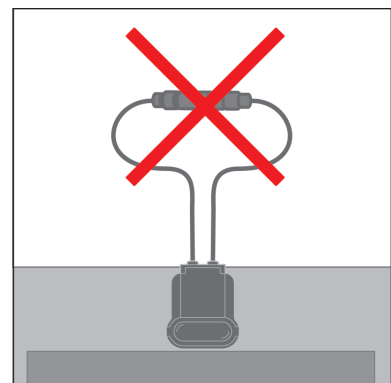
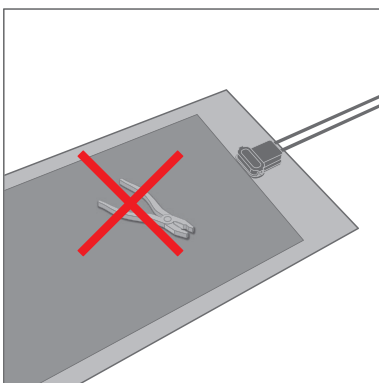

INSTALLATION OF HELIASOL ON A FLAT OR SLIGHTLY CURVED ROOF

1. Prepare the mounting surface for installation.

Ensure that the mounting surface is clean and dry – free from dirt, moisture, dust, oil, grease, adhesives, or other contaminants that could prevent or impair the firm adhesion of the solar film to the mounting surface. If the mounting surface is dirty, clean it with material- or surface-specific cleaning agents.

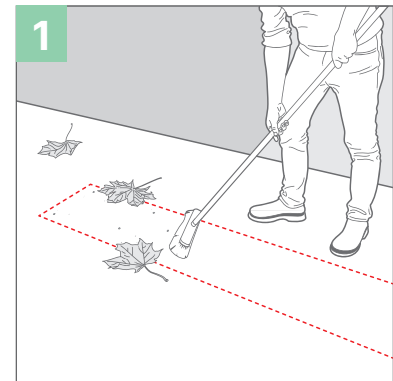

2. Place the solar film in the mounting position for alignment.

Align the solar film and mark the corners and sides of the solar film with a marker. Ensure that the solar films are aligned parallel to each other to avoid overlapping modules. We recommend leaving a gap of at least 5 mm and a maximum of 60 mm between the modules to compensate for slight non-parallelism after securing the first part of the module (see point 4 below). Do not remove the protective films yet.

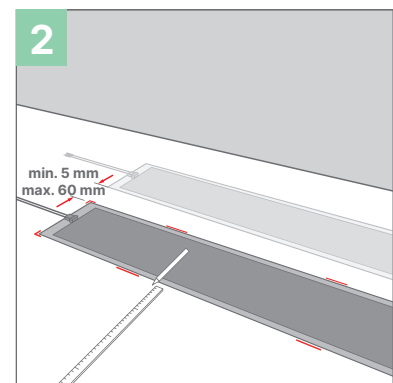

3. Remove the protective film from the back adhesive and check the alignment of the solar film.

Start at the edge of the solar film opposite the junction box. Peel off the protective film from the back adhesive for a length of about 30 cm, starting from one corner. Check the alignment of the solar film using your markings. Place the solar film with the exposed adhesive side facing the mounting surface.

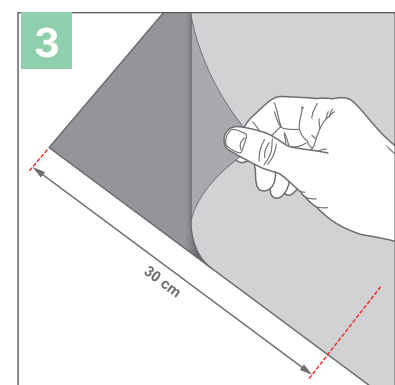

Ensure that the solar film is aligned with the markings, and lightly press the edges of the solar film against the mounting surface with your hand to fix it in the correct position.

CAUTION

Once the solar film is attached to the substrate material, correcting its position is no longer possible without damaging the solar film.

4. Secure HeliaSol on the mounting surface, starting from the side opposite the junction box.

Use a silicone roller to fix the exposed adhesive area (about 30 cm) of the solar film to the substrate. Work from the center of the film towards the edges to ensure that no air is trapped under the solar film.

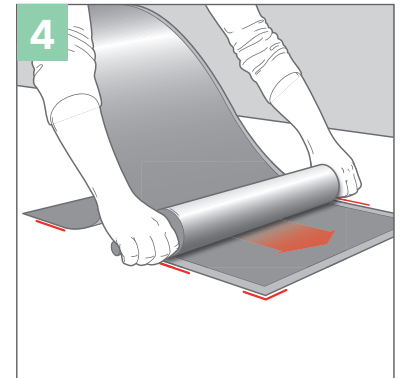

5. Carefully remove the protective film from the back adhesive and work your way towards the junction box.

Remove the protective film from the back adhesive for an additional 20 cm. Use a silicone roller to secure this part of the solar film to the substrate. Ensure that the solar film is evenly attached to the surface by moving the silicone roller across the entire width of the solar film and ensuring that the silicone roller always makes first contact with the solar film on the surface.

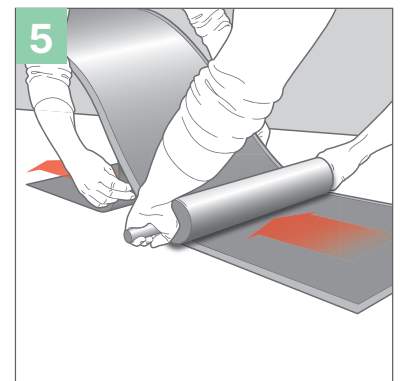

Work towards the junction box. Repeat step 5 until the area around the junction box is reached.

6. Secure the junction box and the remaining area of the solar film on the mounting surface.

Remove the protective film from the front.

Press the junction box firmly by hand to fix it to the mounting surface. Use the silicone roller to secure the remaining area of the solar film around the junction box. Start with the already adhesive area and work towards the edges to avoid air pockets beneath the solar film. Remove the protective film from the front. Your HeliaSol is now ready for use.

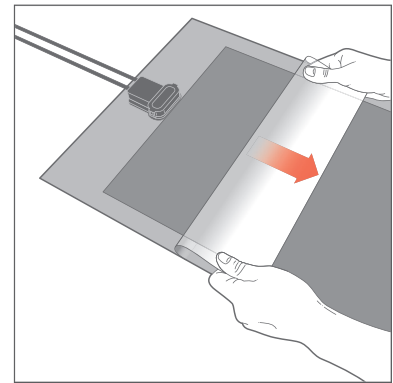
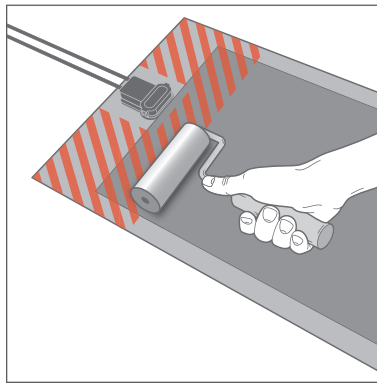
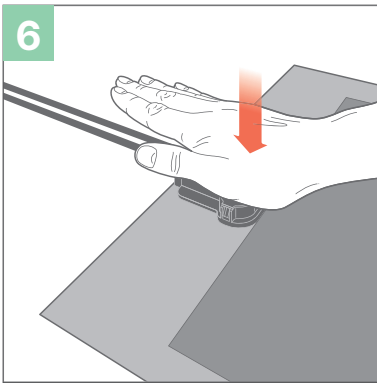

INSTALLATION OF HELIASOL ON A FAÇADE OR PITCHED ROOF

1. Prepare the mounting surface for installation.

Ensure that the mounting surface is clean and dry – free from dirt, moisture, dust, oil, grease, adhesives, or other contaminants that could prevent or impair the firm adhesion of the solar film to the mounting surface. If the mounting surface is dirty, clean it with material- or surface-specific cleaning agents.

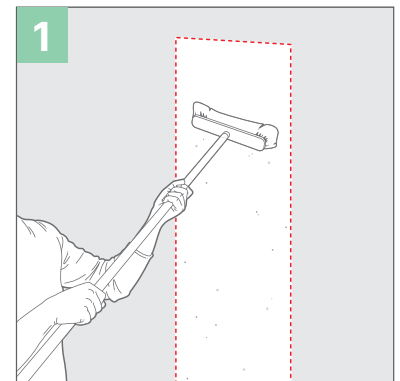

2. Place the solar film for alignment at the mounting position.

Align the solar film and mark the position of the corners and sides of the solar film with a marker. Multiple solar films should be laid parallel to each other, with a gap of at least 5 mm and a maximum of 60 mm between their edges. Do not remove the protective films yet.

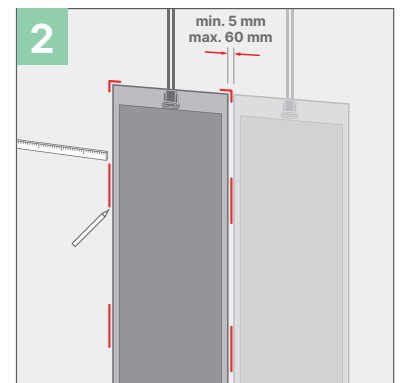

3. Remove the protective film from the back adhesive and check the alignment of the solar film.

Peel off the protective film from the back adhesive for a length of about 30 cm, starting from one corner.

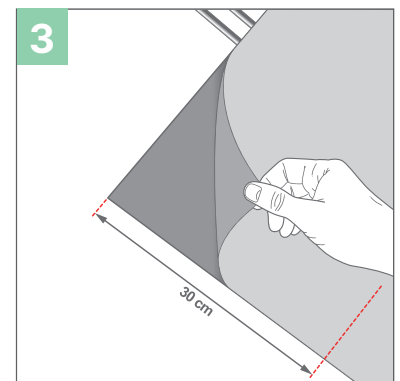

4. Place and align HeliaSol on the mounting surface. Secure the edges and the junction box.

Place the solar film on the mounting surface with the exposed adhesive side facing down. Both horizontal and vertical arrangements are allowed. You can orient the junction box either upwards or downwards.

Ensure that the solar film is aligned with the markings, and lightly press the edges of the solar film against the mounting surface with your hand to fix it in the correct position.

If the junction box is oriented upwards, press the junction box firmly by hand to fix it to the mounting surface.

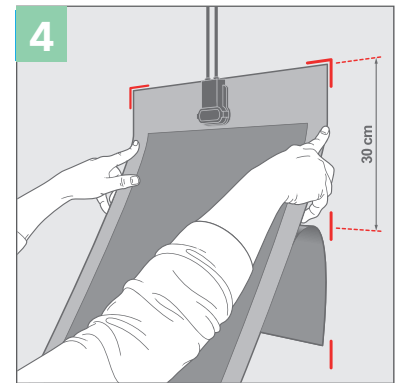

5. Secure the edge of HeliaSol on the mounting surface.

Use a silicone roller to fix the exposed adhesive area (about 30 cm) of the solar film to the substrate.

Work from the center of the film towards the edges to ensure that no air is trapped under the solar film.

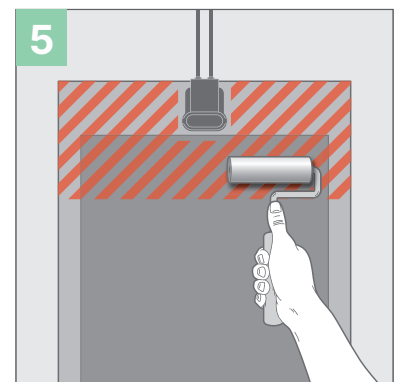

CAUTION

If, during installation, you notice that a solar film is misaligned compared to the desired position, do not attempt to correct its position. Once the solar film is fixed to the mounting surface, correcting its position is no longer possible without damaging the solar film.

6. Carefully remove the protective film from the back adhesive and secure the solar film to the mounting surface.

Gently peel off the protective film from the back adhesive for a length of 20 cm. Use a silicone roller to secure the rest of the solar film to the substrate, starting with the already adhered area. A second person can help ensure that the exposed part of the back adhesive does not come in to contact with the mounting surface.

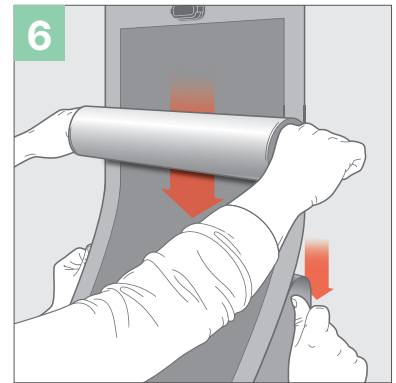

Repeat step 6 until the solar film is fully secured. Ensure that the silicone roller always makes first contact between the solar film and the surface. Make sure the solar film is evenly fixed to the surface by moving the silicone roller across the entire width.

7. Remove the protective film from the front.

Your HeliaSol is now ready for use.

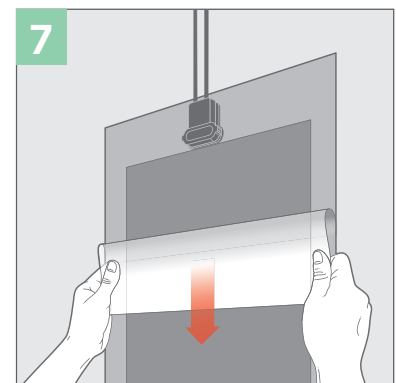

INSTALLATION OF THE INVERTER

For the installation of the inverter, please refer to the included manufacturer's installation guide. Be sure to follow all safety and installation instructions to ensure a proper installation.

4.6 WIRING

For the use of the solar system, the supplied 8-1 connection cable must be used.

CAUTION

Improper use can pose a danger to life and health!

Ensure that the connectors are fully locked and connected. Do not loosen, alter, or modify the factory-installed connections of the junction box. Do not attempt to open the junction box or remove it from the solar film.

Make sure that the connectors remain clean and dry until the connection is made. It is recommended to use dust caps if the connectors need to remain exposed.

Contaminants can cause fires. Ensure that the connectors are protected from dirt and moisture between transport to the installation site and the electrical connection.

Do not use power strips, cable reels, and/or extension cords to connect the Heliakit to the grid. Use only an AC cable compatible both with the inverter and the electrical outlets of your grid.

Only one plug-in solar device is allowed to be connected to each connection user installation (home network), meaning only one Heliakit and no other plug-in solar devices from different manufacturers at the same time.

All modules must be connected to the 8-1 cable; no connectors should remain open.

When laying the connection cables, a minimum bend radius of 40 mm must be maintained and the cables must be permanently secured with suitable cable fasteners. The cable routing must be secured with strain reliefs to ensure that no mechanical or other stresses are applied to the junction box or the solar film. The cables must be mechanically secured between the junction box and the nearest bend of the cable on the substrate, cable conduit, or other structural components with sufficient stability. The junction box must not be opened.

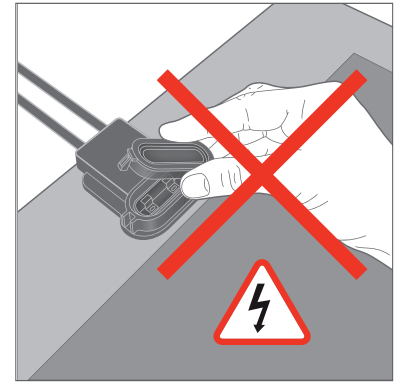
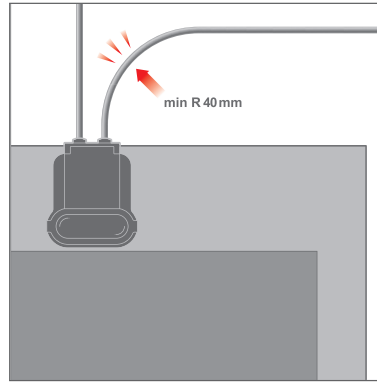
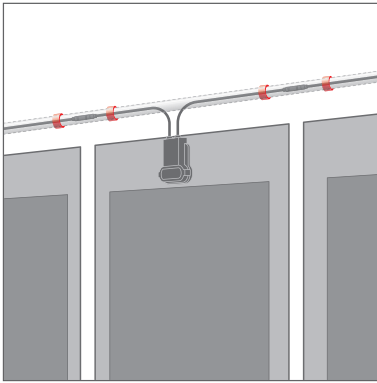

CAUTION

Do not short-circuit the solar films by connecting their connectors together.

The Heliakit includes two pairs of 8-1 connection cables. Use only these cables to connect the modules to the inverter.

One of the two 8-module groups of your Heliakit should be wired according to the diagram provided.

This group will then be connected to the inverter, using the DC extension cable if necessary. For details, please refer to the inverter's guide.

The second 8-module group should be handled in the same way.

Only use the inverter supplied with the Heliakit.

Do not bridge the two 8-1 cable pairs by cross connecting any modules between them.

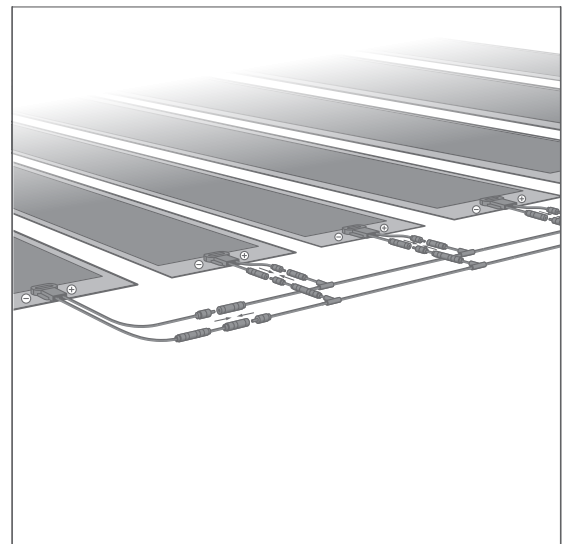

4.7 INITIAL OPERATION

For the initial operation of the inverter, please refer to the Quick Installation Guide and the installation guide provided by the inverter manufacturer. The inverter and AC cable included in the Heliakit have been selected for use in Germany. They are designed for a grid frequency of 50 Hz, a voltage of 230 V,

and come with a Schuko (Type F) plug. Before installation, it is essential to independently verify that the grid frequency, voltage, and plug type are compatible with the local electrical standards in the respective country of use.

4.8 SYSTEM REGISTRATION

Please check if the system must be registered with either your utilities provider or an administration body. Compliance with applicable regulations and requirements is the responsibility of the installer or system owner.

5 MAINTENANCE

To ensure safe and effective operation of the system, the solar films must be carefully and properly inspected, cleaned, and maintained at regular intervals or in the event of special conditions (e.g., extreme weather conditions).

CAUTION

All inspection, cleaning, and maintenance work must be carried out only when the system is turned off (in open-circuit condition) and under low radiation intensity.

Any changes and/or replacements of any kind must only be made after consultation with and instructions from Heliatek.

5.1 SYSTEM INSPECTION

For all installations, a regular (visual) inspection for damage or undesirable changes that could lead to damage to the solar films is required at least once every 12 months.

Additionally, the system must be inspected:

- When the inverter displays error messages indicating faults in the solar film, or if the system's performance seems to significantly decline.
- After extreme weather events (sandstorms, heavy hail, heavy rain, flooding, etc.).
- If there is suspicion that unauthorized persons may have gained access to the system.
- Each inspection should be documented to record any changes.

How to inspect the solar films:

1. Turn off the system by unplugging it from the socket, secure it against accidental activation, and check the system for any residual current.
2. Check for:
 - Secure attachment of all system components.
 - Secure connections, clean and undamaged electrical components.
 - No standing water around the junction box.
 - Visual inspection for delamination, defects, or similar issues.
3. Keep the solar film clean and free from dirt. For further information on cleaning, please refer to the relevant section.
4. In case of snowfall, ensure that the load on the solar films is within the design load range by removing the snow.

CAUTION

Always turn off the system before performing maintenance.

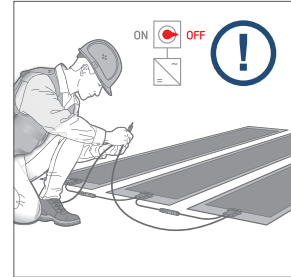

If there are doubts about the condition of the solar films, the affected parts should be documented with photos and sent along with the serial number and wiring details to solar@igepagroup.com. The serial number can be found on the nameplate or is printed at the end of the solar film, opposite the junction box. The system or the affected areas must then be immediately secured so that only maintenance personnel can access them. Further actions should be clarified with the relevant team.

5.2 CLEANING

The solar films are equipped with a front protective film that allows ordinary dust or dirt to be washed away by normal rainfall, which is best achieved when the modules are installed at an angle of 25 degrees or more to the horizontal plane.

When cleaning is performed to maximize system performance and ensure long-term performance, please ensure that the system is turned off (unplug the power cord) and secured against accidental activation, and check the system for any residual voltage.

Carefully clean each solar film with deionized water and a lint-free cloth. First, let the water clean the surface, then use the damp cloth to clean areas that are still dirty. Do not apply excessive pressure, as this could permanently damage the solar film.

For stains like bird droppings, you can use isopropanol, ethanol, or water to clean the surface. Any type of surface contamination can lead to uneven stress, potentially resulting in hotspot formation or reduced power output, which may permanently damage the solar film or impair long-term performance.

CAUTION

Start early in the morning or late in the afternoon when sunlight is at its lowest.

Partial direct shading during cleaning can cause permanent damage to the solar cells due to reverse currents, even in low light conditions, if the system is not turned off.

Do not step on the solar film while cleaning, as shoes with heels may have sharp or hard edges that can scratch or penetrate the modules.

Do not use pressure washers.

Do not use abrasive cleaning agents or cleaning solutions containing acids such as hydrochloric acid, D-limonene, ammonia, or sodium hydroxide.

Do not use water near the junction box.

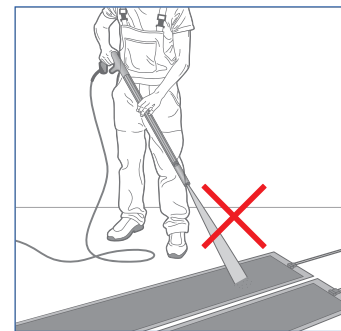

6 DISASSEMBLY AND DISPOSAL

CAUTION

All decommissioning activities must only be carried out after the system has been disconnected from the home grid. After that, the following instructions, as well as the instructions in the inverter guide, apply.

Solar films that are no longer suitable for safe operation (e.g., damaged or defective) or no longer meet the intended goals must be safely removed from the system and disposed of in accordance with local recycling and disposal regulations.

6.1 DISASSEMBLY

The back adhesive of HeliaSol ensures a firm and permanent bond to the surface. Please note that removing the solar film will permanently damage it.

To safely and without unnecessary risk remove the solar film from the surface:

1. Turn off the system (unplug from the socket), secure it against accidental activation, and check the system for any residual voltage.
2. Identify the solar film to be removed and mark it.
3. Disconnect all cables from the solar film using the supplied tool for opening the connector.
4. To remove the back adhesive from the surface, preferably heat the adhesive layer with a heat gun to up to 100°C.
5. Slowly and completely peel off the solar film. Remove the films at a flat angle.
6. If adhesive residue remains on the surface, a petroleum-based adhesive remover can be used. To moisten the residue, apply the remover and wait at least 2 minutes before removing the remaining material with a spatula or similar tool. The use of the adhesive remover can be repeated if residue remains on the applied surface. Use a towel and isopropanol for final cleaning. For porous or other rough surfaces (e.g., concrete walls), a pressure washer may be considered as an alternative to using solvents.

Please note that when removing a solar film, optical differences between the surface covered by the solar film and the surrounding uncovered surface may occur, as HeliaSol protects the underlying material from weather conditions. For coated metal surfaces, a new coating may be required after the complete removal of the films.

6.2 DISPOSAL

The solar films do not contain components (e.g., toxic materials) that require special attention during disposal. They can be treated like any other electronic waste and must be taken to the local recycling and disposal center or another facility responsible for recycling and disposal in accordance with local regulations.

For further information, please contact your local recycling and disposal center or reach out to us at: solar@igepagroup.com.

CAUTION

Do not dispose of the solar film in regular household waste.



7 CERTIFICATES & DATA SHEETS

https://www.heliatek.com/fileadmin/user_upload/pdf_documents/Datasheet_HeliaSol_436-2000_Website_DE.pdf

<https://emea.apsystems.com/document/ez1-spe-datasheet/>

https://www.certipedia.com/certificates/60163910?locale=en&page_number=4

APPENDIX 1: CHECKLIST FOR HELIASOL INSTALLATION

NOTE

This checklist supplements the product's user guide but does not replace it: Always refer to the user guide for a proper and safe installation of HeliaSol.

Before installation		
<input type="checkbox"/>	1.1.	<p>Receiving and Storing</p> <ul style="list-style-type: none"> o Ensure the packaging cartons are not damaged. o Store in a ventilated warehouse with dry air. Temperatures exceeding 25°C should be avoided. o Keep the stretch film wrapped around the shipment to protect it.
<input type="checkbox"/>	1.2.	<p>On-Site Inspections</p> <ul style="list-style-type: none"> o Substrate check as per Chapter 4.4. o Module tilt >1°. o Minimum radius for single-axis module bending: R >50 cm. o Avoid standing water at the locations where the modules are to be installed. o No shading of the modules.
<input type="checkbox"/>	1.3.	<p>Final Preparations</p> <ul style="list-style-type: none"> o HeliaKit received. o Provide appropriate cable conduits. o Provide primer (if required). o Weather check on the installation day (temperature, wind speed, precipitation).

Installation Process (see Chapter 4.5)		
<input type="checkbox"/>	2.1.	<p>Substrate and Weather Conditions</p> <ul style="list-style-type: none"> o Clean the substrate (free from dirt, moisture, dust, oil, grease, adhesives, moss, paint flakes, corrosion, or other particles) o Allow the substrate to dry o Weather check for module adhesion (rain, snow, or strong winds) o The substrate temperature should be above 8°C o Mark and determine the positions of the modules
<input type="checkbox"/>	2.2.	<p>Compliance with Local HSE Safety Regulations</p> <ul style="list-style-type: none"> o Insulating gloves o Safety shoes o Helmet o Mask (if required) o Unauthorized persons must not have access to the work area
<input type="checkbox"/>	2.3.	<p>Installation</p> <ul style="list-style-type: none"> o Follow the alignment and positions from the planning documents o Apply primer (if required) according to the user guide o Install the modules as per the user guide o Never short-circuit HeliaSol modules
<input type="checkbox"/>	2.4.	<p>Final Measures</p> <ul style="list-style-type: none"> o Remove the protective film from the front of all modules. o Collect and recycle waste. o Perform a functional check.
After installation		
<input type="checkbox"/>	3.1.	If needed: Registration in the Market Master Data Register
<input type="checkbox"/>	3.2.	Follow the guidelines for system inspection (see: Chapter 5.1).
<input type="checkbox"/>	3.3.	Follow the guidelines for module cleaning (see: Chapter 5.2).



IGEPA group GmbH & Co. KG
Heidenkampsweg 74-76
D-20097 Hamburg
Deutschland

Tel: +49 (0) 40 7277880
Mail: solar@igepagroup.com