

# INVERCOTE® G

Facts, figures and properties.  
Product specification for Invercote G.

HOLMEN

# INVERCOTE G

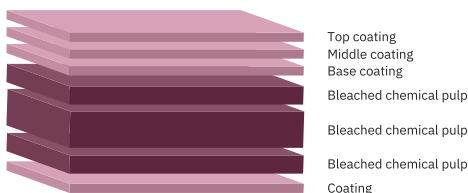

- Top coating
- Middle coating
- Base coating
- Bleached chemical pulp
- Bleached chemical pulp
- Bleached chemical pulp
- Coating

## Solid Bleached Board

Invercote is a multi-layered product (solid bleached board, SBB), entirely based on fresh fibres. Specific fibre compositions are used for the various layers in the construction to optimise performance. The outer layers are dominated by hardwood fibres to promote smoothness and printability. The middle layers consist of softwood fibres for strength and flexibility.

## Product description

Invercote G is designed for prestige packaging applications and high-end graphical designs where an exceptional aesthetic effect is desired. Invercote G has an ultra-smooth surface with a triple-coated print side that are tailored to reproduce print images and meet the high demands of foil and film lamination, the reverse side is single-coated. It has a matt finish on both sides, excellent whiteness and a patented coating formula that provides outstanding lightfastness, giving the end products a longer life. Invercote G is suitable for aroma and flavour sensitive products as well.

The 180 and 200 g/m<sup>2</sup> grammage versions are produced without reverse side coating. Invercote G is also available as linen embossed sheets in all grammages. Invercote G in the grammages 260-380 g/m<sup>2</sup> are certified as industrially biodegradable and compostable in compliance with the demands in the Directive EN 13432:2000.

## Invercote/Inverform Certifications & Standards

Product related				
PEFC credit material	FSC® Mix	Food safety	Archiving	Toy safety
2778 PEFC	TUEV-COC-000232	EC 1935/2004 EC 2023/2006 FDA 21 CFR German BfR XXXVI	Acid free	EN 71 Part 3 EN 71 Part 9

All fibres from sustainable and controlled sources in compliance with the EU Timber Regulation EC 995/2010.

EcoVadis Platinum Medal awarded in 2023 (top 1% of all companies assessed).

Recyclable according to CEPI Recyclability Test Method- Standard Paper Mill Version 2.

### Mill related

ISO 9001

ISO 14001

ISO 45001

ISO 50001

FSC®

FSSC 22000

For more detailed information about our certificates, visit [iggesund.com/certificates](https://www.iggesund.com/certificates).

## Properties - Print side

		Tolerances	Methods/Remarks
Grammage (g/m <sup>2</sup> )	180-380	+/-4%	ISO 536
Colour L* - PS	96.7	+/-0.8	ISO 5631-2
Colour a* - PS	2.3	+/-0.6	ISO 5631-2
Colour b* - PS	-7.9	+/-1.1	ISO 5631-2
Whiteness - PS (%)	129	+/-5	ISO 11475
ISO Brightness R457 - PS (%)	94	+/-2	ISO 2470
Surface roughness PPS - PS (µm)	0.9	≤1.4	ISO 8791-4
Board gloss 75° - PS (%)	40	+/-10	ISO 8254-1
Surface strength IGT blister - PS (m/s)	0.7	≥0.5	ISO 3783
Surface strength IGT pick - PS (m/s)	1.3	≥0.8	ISO 3783
Cobb - PS (g/m <sup>2</sup> )	30	≤40	ISO 535

## Properties - Reverse side

		Tolerances		Tolerances	Methods/Remarks
Grammage (g/m <sup>2</sup> )	180-200	+/-4%	220-380	+/-4%	ISO 536
Colour L* - RS	96.4	-	96.5	-	ISO 5631-2
Colour a* - RS	2.0	-	1.6	-	ISO 5631-2
Colour b* - RS	-5.0	-	-7.0	+/-1.1	ISO 5631-2
Whiteness - RS (%)	110	-	122	-	ISO 11475
ISO Brightness R457 - RS (%)	90	-	94	-	ISO 2470
Surface roughness PPS - RS (µm)	-	-	5.0	≤7.0	ISO 8791-4
Cobb - RS (g/m <sup>2</sup> )	30	≤40	30	≤40	ISO 535

## Common properties

		Tolerances	Methods/Remarks
Grammage (g/m <sup>2</sup> )	180-380	+/-4%	ISO 536
Moisture content (%)	6.0	+/-1.0	ISO 287
Ply bond (J/m <sup>2</sup> )	160	≥120	Tappi 569
Robinson taint	<0.6	-	EN 1230, DIN 10955

Robinson taint value is below the detection limit of 0.6.

## Grammage dependent properties

												Tolerances	Methods/Remarks
Grammage (g/m <sup>2</sup> )	180	200	220	240	260	280	300	330	350	380		+/-4%	ISO 536
Thickness (µm)	205	235	260	300	330	360	395	435	465	505		+/-4%	ISO 534
Caliper (pt)	8.1	9.3	10.2	11.8	13.0	14.2	15.6	17.1	18.3	19.9		-	-
Opacity (%)	94.0	95.6	97.0	97.6	98.0	98.4	98.6	98.8	99.0	99.2		-	ISO 2471
Bending stiffness L&W 5° - MD (mNm)	5.5	8.2	11.9	16.2	20.8	29.9	38.5	50.8	61.8	77.9		-	ISO 5628
Bending stiffness L&W 5° - CD (mNm)	2.5	3.7	5.4	7.5	9.7	12.5	16.0	21.0	25.0	31.0		-	ISO 5628
Bending resistance L&W 15° - MD (mN)	65	95	140	190	245	315	405	550	650	820		-15%	ISO 2493-1
Bending resistance L&W 15° - CD (mN)	30	45	64	83	107	137	180	230	275	345		-15%	ISO 2493-1
Bending moment Taber 15° - MD (mNm)	3.1	4.6	6.8	9.2	11.8	15.2	19.6	26.5	31.4	39.6		-	-
Bending moment Taber 15° - CD (mNm)	1.4	2.2	3.1	4.0	5.2	6.6	8.7	11.1	13.3	16.7		-	-
Tensile strength - MD (kN/m)	17.0	18.5	20.0	21.5	23.0	24.0	25.5	28.0	29.5	31.0		-	ISO 1924-2
Tensile strength - CD (kN/m)	9.5	10.0	10.5	11.0	11.5	12.0	12.5	13.5	14.0	14.5		-	ISO 1924-2
Tearing resistance - MD (mN)	2000	2300	2700	3100	3300	3700	4300	4700	5200	6400		-	ISO 1974
Tearing resistance - CD (mN)	2000	2350	2800	3300	3600	4000	4600	5100	5600	6400		-	ISO 1974

Last updated 30 Nov 2022

Bending Moment Taber is a calculated value based on a correlation factor of 20.7.

## Test methods

All properties are measured in test climate 23°C/50% RH at Iggesund mill. Tolerances and max/min levels, when stated, are based upon 95% confidence interval within each production run. Read more about testing methods in our section about [General Technical Information](https://www.iggesund.com/insights/paperboard-know-how/general-technical-information/) (<https://www.iggesund.com/insights/paperboard-know-how/general-technical-information/>).

## Online version

Access the online version of this spec sheet on:  
[iggesund.com/invercote-G](https://www.iggesund.com/invercote-G)





# ABOUT INVERCOTE®

This is a summary of information about Invercote including applications and benefits, sustainability advantages, technical details and creasing recommendations.

**HOLMEN**

# ABOUT INVERCOTE

No compromises, shortcuts, or limitations – the Invercote family of paperboard invites you to explore a world of creative freedom. Invercote offers a unique combination of premium quality, aesthetics, and sustainability performance, all the way from the forest to the confident shelf appearance. Made with the utmost expertise, it enables you to create packaging with superior design and a low climate impact.

## Applications and benefits

Invercote is a strong, multi-layered Solid Bleached Board (SBB) that is ideal for a range of end-user applications including the packaging of premium cosmetics, perfumes, chocolate, pharmaceuticals, electronics and many other products. It is also widely used for high-quality brochures and printing graphics. Invercote is designed to meet the highest demands of image reproduction and surface treatment methods such as foil and film applications

Invercote paperboard has high strength and stiffness, which are major advantages when designing and processing packages. It also ensures good brightness and is a hygienic product that is odour and taint neutral. All materials used in the making of Invercote are approved for food contact, making it highly suitable for the packaging of food and other sensitive products.

## Sustainability advantages

Invercote is manufactured in Iggesund, Sweden from fresh wood fibres of known and traceable origin from sustainably managed forests. The Holmen mill in Iggesund holds chain-of-custody certification and has an extremely low climate impact due to its energy self-sufficiency. The mill received the EcoVadis Platinum rating for the third year in a row 2023, which recognises the paperboard mill as a global leader in sustainability that belongs to the top 1 per cent of all companies assessed by EcoVadis.

## Technical details

Invercote's multiple layers of solid bleached fresh fibre give it superior strength and stiffness compared to board grades containing mechanical or recycled fibres, or single-ply bleached fresh fibreboards. The fibre composition varies for each layer in the construction of Invercote. The fibres are selected based on shape and length and are treated differently to tailor the paperboard construction for its intended use.

The fibre layers form an excellent base for coating and at the same time provide the ideal construction for bending and folding. A mineral coating is applied in two or three steps to ensure smoothness for printing and foiling applications. Deep and narrow creases can be achieved as well as detailed embossing.

Invercote can be printed on using several conventional methods and digital printing processes. Its strength and consistent baseboard performance, enable full-speed printing and post-print production. Invercote can be glued with both emulsion adhesives (water based) and hot melt adhesives.

# Creasing recommendations

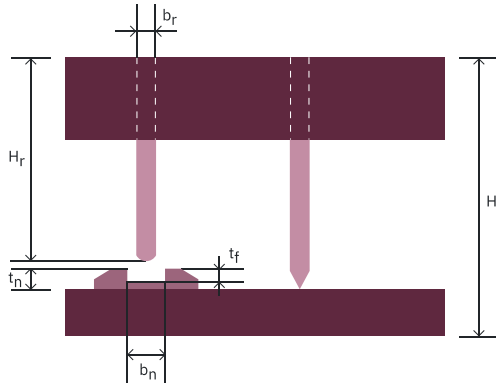

Observe that these are general recommendations and adjustments might be necessary in each case.

Height of cutting rule,  $H=23.8$  mm Groove depth,  $t_f = t_n - 0.1$  mm

Paperboard Thickness ( $\mu\text{m}$ )	Groove width, $b_n$ (mm)	Matrix thickness <sup>1)</sup> , $t_n$ (mm)	Creasing rule	
			Height, $H_r$ (mm)	Thickness, $b_r$ (mm)
205	0,9	0,5	23,4	0,70
235	1,0	0,5	23,4	0,70
270	1,0	0,5	23,4	0,70
300	1,0	0,5	23,3	0,70
330	1,1	0,5	23,3	0,70
360	1,2	0,6	23,2	0,70
395	1,2	0,6	23,2	0,70
435	1,3	0,6	23,2	0,70
465	1,3	0,6	23,2	0,70
505	1,4	0,7	23,1	0,70
520	1,8	0,8	23,0	1,0
600	1,9	0,9	22,9	1,0
660	1,9	0,8	22,9	1,0
720	2,2	0,9	22,8	1,4
790	2,4	1,0	22,7	1,4
870	2,6	1,1	22,6	1,4
930	2,7	1,2	22,5	1,4
1010	2,9	1,3	22,4	1,4
1) Matrix (Pertinax)				



Access the online version of this spec sheet on:  
[iggesund.com/about-invercote](https://iggesund.com/about-invercote)



# GENERAL TECHNICAL INFORMATION

This is a collection of technical information designed to give you a general picture about everything from product safety regulations to sustainability performance and paperboard terminology.

**HOLMEN**

# Table of contents

Introduction	3
Paperboard handling	8
Sheet and reel tolerances	10
Reel join	13
Pallets for sheet deliveries	15
Terminology	16
Test methods	19
Product and use	25
Typical applications for our paperboard	29

# GENERAL TECHNICAL INFORMATION

## Introduction

How is the paperboard quality tested? Which EU regulations apply to paperboard material and how are our products evaluated according to sustainability standards and certifications? General Technical Information is a collection of technical information designed to give you a general picture about everything from product safety regulations to sustainability performance and paperboard terminology.

This information includes an overview of various kinds of paperboard and advice about how the paperboard material should be handled to achieve the best possible results. The recommendations and advice are designed to help you in selecting and using our three product families: Invercote, Incada and Inverform. If you are interested in complete and updated product specifications, go to [iggesund.com/products](https://iggesund.com/products).

We hope that our product information will make it easy for you to find a product that fits your needs and specifications. The specifications are regularly updated online. If you have a specific question about our material or products, please contact our customer service.

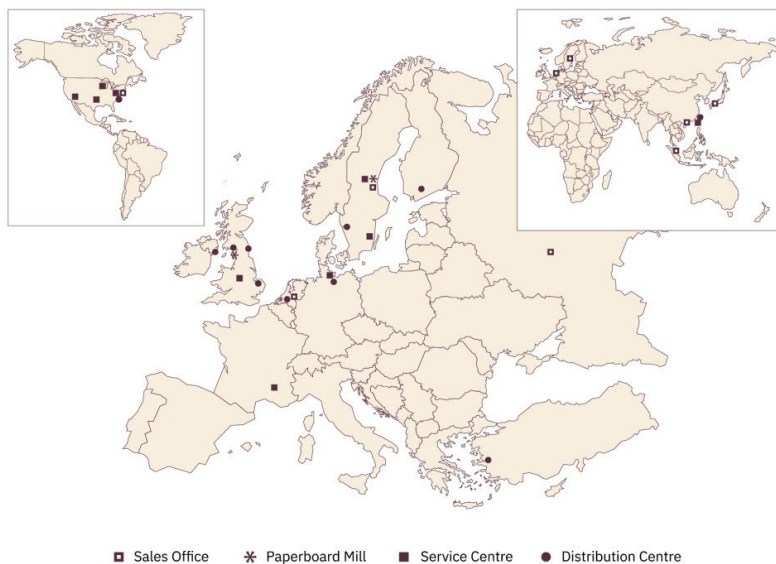

## Contact us

To find a local Holmen Board and Paper representative please go to the contact page on [iggesund.com/contacts](https://www.iggesund.com/contacts) (<https://www.iggesund.com/contact-and-support/contact-us/contacts/>) or call one of the numbers below.

Switchboard numbers:

Europe, Amsterdam, Netherlands  
+31 20 655 9200

Lyndhurst, United States  
+1 201 804 99 77

Workington, United Kingdom  
+44 1900 601000

Asia  
Hong Kong  
+852 2516 0250  
Singapore  
+65 6392 8600  
Japan  
+81 3 3560 3068

## Made in Sweden and England

Holmen manufactures a range of paperboard products at the Holmen Iggesund Mill and the mill in Workington, England. We also offer plastic extrusion and various kinds of lamination in combination with our paperboard. All our facilities have been production units for the better part of a century thus advancing the craft, performance and production methods of our paperboard products.

### Unique knowledge accompanies every order

To achieve the best results in the printing process or in packaging manufacture, you need not only a high quality base material, but also knowledge about how to use that material in the best possible way. Brand owners, designers, packaging developers and printers all contribute their own specific knowledge and experience to help optimise the product's properties and functions throughout its lifespan. For this reason, hands-on knowledge about the special properties of paperboard is also required.

### Our service offer

All sales of Holmen's products in Europe are coordinated at our sales office in Amsterdam. We also have sales offices in Singapore, Hong Kong, Japan and the United States. We have organised our people, technology, and systems to suit your priorities and offer complete commercial and technical customer support.

We know that customers' needs constantly evolve, and market conditions are ever-changing.

The service we provide is based on some simple principles:

- Locally based account managers and technical service managers. Account coordinators in the sales office in Amsterdam speak different European languages.
- Sheeting facilities close to our main markets, as well as at our mills, ensure the rapid delivery of small orders.
- Storage facilities close to our customers.
- A wide network of selected merchants supplement the sales network.

### Quality assurance

We have implemented Quality Assurance Systems to maintain our product quality and to meet customer needs and expectations. At our mills we have certified quality assurance systems in accordance with ISO 9001. We welcome customer audits to approve and further develop our quality system. Product specifications and contracts are essential elements for ensuring that we have agreements between our customers and ourselves, which meet the need for clear, joint understandings about product quality. We believe that quality has a broader meaning and includes how the paperboard is made and how it impacts our planet. Therefore, our paperboard is also certified according to ISO 14001 and ISO 45001.

## Product safety

The essential purpose of packaging is to ensure the hygiene and quality of the packed product. We control the entire pulp and paperboard chain production so that we can supply paperboard products which meet strict standards for hygiene, barrier functions, and taint and odour neutrality. All materials used in the making of our board are approved for food contact in accordance with current regulations in different countries. To ensure that we are providing the correct product and product safety documentation we must know the intended final application. If your specific applications require productsafety certificates or if further information is needed, please contact your local Technical Service Manager

## Compliance, accreditations and awards

Packaging in general, paperboard and paperboard-making processes are all subject to environmental attention. As a paperboard supplier, we take responsibility for the environmental impact of our products all the way from the sourcing of raw materials through our manufacturing processes.

Environmental management systems are implemented at all our mills (ISO 14001). The Holmen Group's forest management routines are approved in accordance with the FSC® (<https://www.holmen.com/en/sustainability/our-sustainability-work/permits-certificates-management-systems/holmens-license-number/>) and PEFC™ (PEFC/05-33-105 (<https://www.holmen.com/en/sustainability/our-sustainability-work/permits-certificates-management-systems/holmens-license-number/>)) standards as well as certified in accordance with the ISO 14001 standard. Both our mills hold chain of custody certifications (CoC) in accordance with FSC® and the Iggesund Mill also holds CoC certification with PEFC™. This enables our certified customers to be part of the chain. . Our aim is that our processes will meet environmental requirements with good safety margins and we ensure that our products are safe for handling and use. Both mills operate in accordance with the energy management system standard ISO 50001 and the safety management system ISO 45001.

Packaging waste and associated landfill issues are of major concern in some countries. For a long time, used paper and paperboard have proven to be easy to recover – both as a raw material for recycled fibre products and also for energy recovery.

Holmen's energy use is based on biofuels and we have initiated programmes to further reduce the use of fossil fuels, thereby reducing fossil carbon dioxide emissions.

Paperboard has a low carbon footprint compared to other packaging materials. The raw material, timber, is harvested from managed forests that absorb carbon dioxide and emit oxygen. We measure our carbon footprint according to CEPI guidelines and updated data can be found at [iggesund.com/certificates](https://www.iggesund.com/certificates) (<https://www.iggesund.com/sustainability/our-production/certificates-and-awards/>).

Holmen has reported to the CDP Climate Program since 2007 and also to the CDP Forest Program since 2013. Surveys over the years have shown that Holmen has good management in place and a strategy to reduce the negative impacts of climate change. In the evaluation of forest management, Holmen has been placed in the group for good leadership that ensures sustainable use of the forest's resources for several years now. In the 2021 results, Holmen scored highly in two categories: Climate Change A- and Forests A-.

The Holmen Group has been part of the UN Global Compact and its corresponding Nordic network since 2007. Each year the group reports its sustainability work according to the ten principles of the Global Compact. The principles relate to human rights, social conditions, the right to establish trade unions, environmental responsibility and anti-corruption.

As members of the UN Global Compact, Holmen annually reports a "Communication on Progress" (COP) that describes how its work with Global Compact's principles for responsible business practice is progressing.

Twice in the last decade, Holmen has been included in the Corporate Knights index over the 100 most sustainable companies in the world, Global 100.

The Carbon Disclosure Project (CDP) is the name of an international federation that in 2016 represented 827 institutional investors with assets totalling around SEK 900 billion. CDP seeks to encourage companies around the world to reduce their impact on the climate and nature's resources, and it presents an annual report on the outcome of its work. As a result of its energy investments and the consequent fall in carbon dioxide emissions in 2014, Holmen qualified for the A list on the Climate Performance Leadership Index. The global index lists 187 companies that have been shown to have an excellent strategy for reducing climate change.

For a complete and updated list of certificates, go to [iggesund.com/certificates](https://www.iggesund.com/certificates) (<https://www.iggesund.com/sustainability/our-production/certificates-and-awards/>).

## EcoVadis - third party assessment of CSR data

Holmen mill Iggesund report their CSR data to EcoVadis and have, after undergoing assessment of data from 2020, received Platinum Level in the EcoVadis system. Our mills are among the top one per cent of almost 25,000 companies that are annually assessed by EcoVadis.

The EcoVadis scorecard for each mill can be downloaded at [iggesund.com/certificates](https://www.iggesund.com/certificates) (<https://www.iggesund.com/sustainability/our-production/certificates-and-awards/>).

# Sustainability the Holmen way

## The overall picture

Invercote, Incada and Inverform, the three paperboard families manufactured by Holmen, meet a very high standard from a sustainability viewpoint. They are produced in modern, efficient mills that operate largely on bioenergy. From a wider perspective, it is also obvious that the raw material is renewable and the products are well suited to recycling.

In the European recycling system over 70% of paper-based products are collected and recycled as material or bioenergy.

## Responsible use of resources

At Holmen Iggesund Mill almost 100% of the wood raw material is used. What does not become paperboard becomes energy. Both mills have minimal amounts of waste that goes to landfill – over the years the company has found applications for all the fractions previously considered to be waste.

## Transparency

Holmen Board and Paper is part of the forest industry group Holmen, which has repeatedly been singled out by various institutions as one of the world's 100 most sustainable companies and a role model in fighting climate change. An extensive sustainability audit enables all stakeholders to inspect in detail how the group, and thereby also Holmen Board and Paper, performs. The sustainability audit is done in accordance with the guidelines set by the Global Reporting Initiative (GRI).

The ultimate transparency is created when our customers and the general public are able to roam freely in our forests and see with their own eyes how they are managed.

## The most sustainable material system

Paperboard and paper products are included in a material system in which paper is collected after its primary use, is recycled and can be used again. Perhaps not always in the same applications as the primary fibre but there are many sensible applications for recycled fibre-based material.

However, primary and recycled fibres are not two separate systems. On the contrary, they are mutually dependent. If the inflow of primary fibre ceases, the industry that lives on recycled fibres starts to experience disruptions after only a few months. According to the consulting firm McKinsey, the large-scale addition of primary fibres is required to maintain the quality of the global recycled fibre pool.

You can read more about environmental issues at [iggesund.com/sustainability](https://www.iggesund.com/sustainability) (<https://www.iggesund.com/sustainability/>) and about our social, financial and environmental responsibility in the Annual Report at [holmen.com](https://www.holmen.com/en/investors/Financial-information/reports-and-presentations/) (<https://www.holmen.com/en/investors/Financial-information/reports-and-presentations/>).

# Paperboard handling

The correct handling of paperboard is very important for achieving the best results in printing, converting and use. To ensure this we recommend the following procedures to printers, converters and other users.

## Recommendations to printers/ converters

### Before printing

The paperboard is identified by the order number and the pallet or reel number. It is essential that these numbers are recorded to provide identity and traceability throughout printing, conversion and use.

### During printing/converting

The moisture-proof wrapping must not be removed until the board has attained the temperature of the environment concerned (printing room, etc.)

Pallet or reel weight (kg)	Temperature differences board – printing room (print room temp. about 20°C)		
	10°C	20°C	30°C
400	2 days	2 days	3 days
800	2 days	3 days	4 days
1200	2 days	4 days	5 days

For food packaging and applications, we recommend you remove the outer layer of the reel before printing in order to avoid contaminated board.

When cold paperboard is exposed to a warm environment, the air adjacent to the board can be cooled below its dew point (point of condensation) and this moisture is then absorbed by the board. The time for temperature equilibrium to be established varies depending on the temperature difference and the weight of the board (pallet or reel). Therefore, the wrapper should never be removed before the board has reached the temperature in the printing room.

Recommended climate in the printing/converting room to prevent curl and/or misregistration is 45–60% relative humidity and a temperature of 20–23°C.

The moisture content of paperboard can rise as a result of its exposure to air at high relative humidity, during periods of wet weather. It can also occur as a result of the condensation effect in cold weather discussed above. Moisture absorption can cause waviness at the edges of the sheets and a general tendency is for upcurl, i.e. curl towards the printed surface for high quality sheet fed paperboard. For offset print, please be aware that misregistration may occur together with press misfeeding, wasted sheets and loss of output and efficiency.

The moisture content of paperboard can fall as a result of its exposure to air at low relative humidity. This can occur during very dry weather and also occur in centrally heated buildings when the external air is very dry and very cold. A paperboard which is too dry may also become wavy, develop downcurl, i.e. curl towards the reverse side of the board and become brittle. These features can cause misfeeding and it will be difficult to crease the board satisfactorily.

Avoid rubbing or touching the surface of extruded/ laminated board because the corona treatment can be easily damaged.

## After printing/converting

Paperboard in sheet form should be rewrapped with moisture-proof material after printing.

Rewrapping is particularly important to ensure good register when board is printed in two or more passes through the printing press. It is also important to wrap in this way to achieve good register between the print and the next process, for example, cutting and creasing, guillotining or bookbinding.

Paperboard products should be wrapped in moisture-resistant material after conversion and prior to shipment to the customer (end user) or to further conversion operations.

## Recommendations to end users

### Before use

The supplier's order number identifies the material. Should subsequent traceability be necessary, we recommend that you record this number and maintain the identification of the material.

### Unpacking/Storage

The end user should also observe the precautions regarding the achievement of temperature equilibrium prior to unwrapping and use. See warming up timetable on the previous page. Unused material should be rewrapped.

The end user should rewrap any unused material to avoid an extended period of exposure to the atmosphere in the work environment. Some end users, as a consequence of their process, may have environments that are either excessively damp or excessively dry compared with the acceptable range of 45–60% relative humidity, and in such conditions there would be a tendency for the board to either gain or lose moisture with a consequent change in shape or loss of flatness.

### Recommended time limit for board in storage

Holmen has chosen raw material, chemicals and processes that support stability and long lifetime of the manufactured products, without deterioration of the board properties. However, even if the board is correctly handled, optical as well as physical properties may change with time.

We recommend a maximum 6 (six) month time limit, from delivery, for board in storage.

Please contact your Technical Service representative for advice about the possibility of using board beyond the recommended maximum time limit.

# Sheet and reel tolerances

	Iggesund Invercote Inverform	Workington Incada	Strömsbruk Extrusion coating Film, foil and board laminated	Sheeting stations/ Service centres
Sheets				
Width (Cross direction (CD) or Slit dimension)	0/+2 mm	0/+2 mm	0/+2 mm	0/+2 mm
Max slit wander	0.25 mm/sheet	0.25 mm/sheet	0.25 mm/sheet	0.25 mm/sheet
Length (Machine direction (MD) or Chop dimension)	0/+2 mm	0/+2 mm	0/+2 mm	0/+2 mm
Squareness	1 mm per metre	1 mm per metre	1 mm per metre	1 mm per metre
Number of sheets/pallet*	±0.5 %	±0.5 %	±5 %	±0.5 %
Number of sheets/ream (ream wrapped, typically 100 sheets)	±3 sheets	±3 sheets	±3 sheets	±3 sheets
Max sheet size	1345 x 1600 mm	1400 x 1600 mm	1350 x 1600 mm	1400 x 1610 mm
Min sheet size	290 x 420 mm		405 x 450 mm	
	Embossed board: 290 x 450 mm		Board laminates: 400 x 550 mm	
Max pallet height	Standard board: 1580 mm (pallet incl.)	1500 mm (pallet incl.)	1580 mm (pallet incl.)	1500 mm (pallet incl.)
	Embossed board: 1250 mm (pallet incl.)		Board laminates: 1140 mm (pallet incl.)	

\* According to information given on pallet or reel label.

	Iggesund Invercote Inverform		Workington Incada		Strömsbruk Extrusion coating Film, foil and board laminated		Sheeting stations/ Service centres	
Reels	≥ 120 mm:	< 120 mm:	≥ 230 mm:	< 230 mm:	≥ 120 mm:	< 120 mm:	≥ 230 mm:	< 230 mm:
Width	±1 mm	0/-1 mm (0/+1 mm and ±0.5 mm by request)	0/+2 mm	0/-0.5 mm	±1 mm	0/-1 mm	±1 mm	0/-1 mm
Length*	±0.5%	±5 metres	±0.5%	±5 metres	±0.5%	±5 metres	±0.5%	±5 metres
Core displacement	< 5 mm	< 2 mm	< 3 mm	< 2 mm	< 5 mm	< 2 mm	< 5 mm	< 2 mm
Diameter, general	Max 1800 mm ± 25 mm		Max 1800 mm ± 25 mm		Max 1800 mm		Max 1200 mm ± 25 mm	
If max diameter specified	+0/-50 mm		+0/-50 mm		+0/-50 mm		+0/-50 mm	

\* According to information given on pallet or reel label.

## Sheet grain direction

Grain results from the fact that fibers flowing onto the paperboard machine align themselves predominantly in the direction of their flow and the moving wire. The direction that is parallel to the flow of fibers on the wire is called the Machine Direction (MD). Direction perpendicular to the machine direction, or across the paper machine wire, is called the Cross Machine Direction (CD). Grain direction is called long-grain (or grain-long) when the longer sheet dimension is the same as, or parallel to, the machine direction. Shortgrain paperboard has its shorter sheet dimension parallel to machine direction. A diagram of each is below:

Long grain 700 x 1000 mm

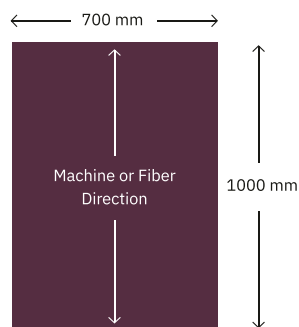

Short grain 1000 x 700 mm

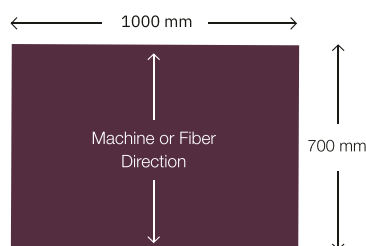

# Tolerances on deliveries

## Quantity based on weight

The delivered quantity is expressed in and based on weight, which is determined at the time the product is manufactured and packed. For deliveries in sheets the net weight is determined meaning the weight of the pallet and wrapping are excluded from the weight. For deliveries in reels the gross weight is determined meaning the wrapping, core and plugs are included in the weight.

Product		Permitted deviation from weight ordered
Invercote and Inverform	All deliveries	±4%
Incada	up to 50 tonnes	±4%
	over 50 tonnes	±2.5%
Plastic coated/laminated products	up to 5 tonnes	±15%
	over 5 tonnes up to 15 tonnes	±10%
	over 15 tonnes up to 25 tonnes	±8%
	over 25 tonnes	±5%

## Quantity based on area

### Invercote

Our products are available in quantities based on number of sheets or metres in length, where the actual area supplied is calculated from the nominal grammage.

Products	Permitted deviation from number of sheets/metres ordered
Invercote Sheets	±0.5%
Invercote Reels	±0.5%

### Incada

Incada products are available in quantities based on number of sheets or metres in length, where the actual area supplied is invoiced in tonnes calculated from the nominal grammage.

## Reel join

Reel join markings as used by Holmen are identified according to the following:

### Iggesund Mill and Strömsbruk

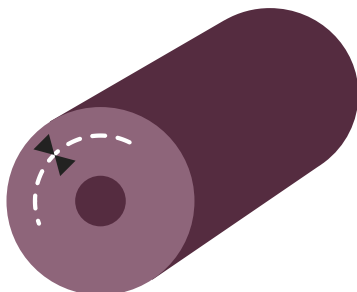

Reel joins are marked by two arrows, above and below each join.

Standard joins are made with a yellow non-printable splicing tape. The tape width is 50 mm and the thickness is typically 0.19 mm. The adhesive is pressure sensitive providing a high cohesive strength. Joins are butt joints with no overlap and are made with a single cross direction (CD) strip of tape on both sides of the board. Machine direction (MD) strips are added on the print side. Other types of tape are available upon request. Please contact your Holmen Board and Paper representative.

### Workington Mill

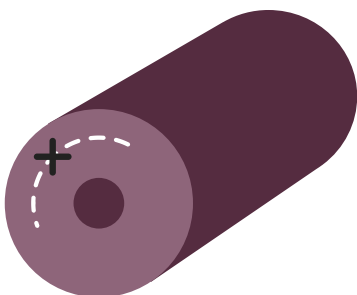

Reel joins are marked by a black cross, centred over each join.

Joins are made with a black printable and repulpable splicing tape. The tape is 75 mm and the thickness is typically 0.1 mm. The adhesive is pressure sensitive giving a high cohesive strength. Joins are butt joints with no overlap and made with a single CD strip of tape on both sides of the board (note: MD straps are not added).

# Restrictions affecting reel diameter

Reel width	Diameter	Wrapping	
Iggesund safety restrictions			
<460 mm		Double packed reels	
460-479 mm	<1101 mm	Single packed reels	
480-489 mm	<1351 mm	Single packed reels	
490-501 mm	<1551 mm	Single packed reels	
502-540 mm	<1651 mm	Single packed reels	
>540 mm	<1800 mm	Single packed reels	
Workington safety restrictions			
<400 mm	>900 mm	Reel will be multipacked.	
		If diameter is <3 times the reel width = single packed.	
>400 mm	>900 mm	If diameter is between 3 and 3.5 times the reel width = single or multipacked. System will allow both options. The customer decides.	
		If the diameter is >3.5 times the reel width = multipacked.	
Strömsbruk safety restrictions			
<600 mm	Max dia 2.3 x width	Single packed	Larger diameters will be double packed.
≥600 mm	Max dia 2.6 x width	Single packed	

For the Iggesund plant, grammages above 300 g/m<sup>2</sup> must be ordered on a 302/305 core.

# Pallets for sheet deliveries

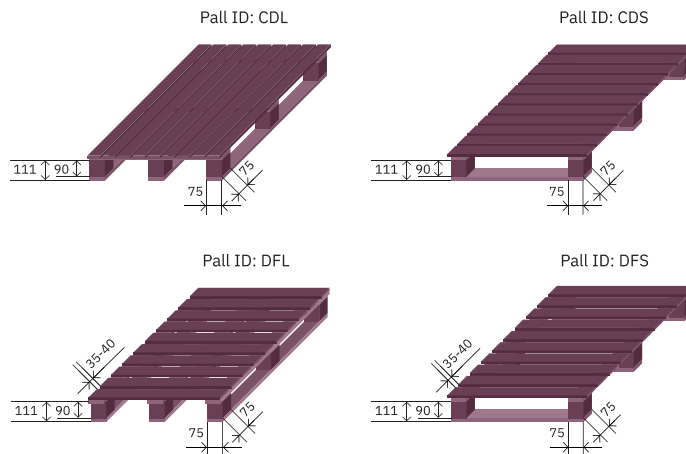

The most frequent pallet types for sheet deliveries used by Holmen Board and Paper.

Code	Version	Description	Code	Version	Description
CD	L	CDL (close deck, runners long)	2CD	L	2CDL (close deck, runners long)
CD	S	CDS (close deck, runners short)	2CD	S	2CDS (close deck, runners short)
DF	L	DFL (direct feed, runners long)	2DF	L	2DFL (direct feed, runners long)
DF	S	DFL (direct feed, runners short)	2DF	S	2DFL (direct feed, runners short)

It is not always possible to deliver certain sheet sizes as single pallets. The option will be twin pallets with the codes 2CDL, 2CDS, 2DFL and 2DFS.

## Transport packaging

Transport packaging is used to maintain the quality of the delivered paperboard and to protect it during handling, transport and storage.

Reels have cores made from recycled paper and core plugs from particle wood. The reels are either packed with the ends protected by corrugated kraft board and stretch wrap or only stretch wrapped. The stretch film is low-density polyethylene. The labels are made of bleached kraft paper and, occasionally, plastic labels are used.

For the Iggesund Mill, pallet packs consist of pallets of 100 per cent wood. For the Workington Mill, the blocks are made of pressed wood. All pallets are covered with a protective polyethylene sheet. The paperboard pile is protected on top by a sheet of polyethylene. The whole pallet is then shrink-wrapped with medium-density polyethylene. Labels are made of bleached kraft paper. Ream packs are made from bleached kraft paper coated with a water barrier (polyethylene 10 g/m<sup>2</sup>). Labels are made of bleached kraft paper.

The materials used for the transport of packaging meet the requirements in the EU Directive EC 94/62. For more detailed information please contact your Holmen Board and Paper representative.

# Terminology

## Holmen's paperboard grades

### Solid Bleached Board (SBB, GZ) Multiply construction, Invercote

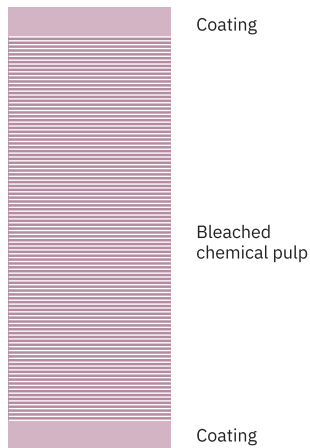

SBB is made exclusively from bleached chemical pulp. It usually has a pigment coated top surface and can also be pigment coated on the back.

### Folding Box Board (FBB, GC2) Cream back, multiply construction, Incada

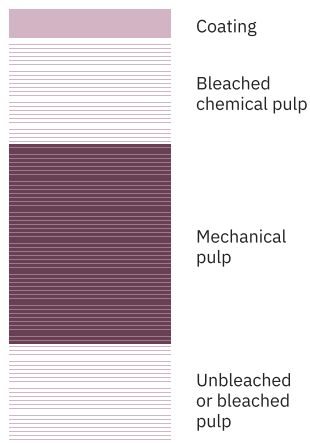

FBB, cream back, is made from layers of mechanical pulp sandwiched between layers of bleached chemical pulp.

## Folding Box Board (FBB, GC1) White back, multiply construction, Incada

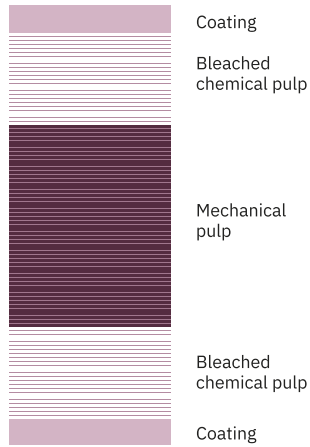

FBB, white back, is made from layers of mechanical pulp sandwiched between layers of bleached chemical pulp. The top layer is pigment coated. The back is thicker than FBB, cream back, and can also be pigment coated.

## Solid Bleached Board, Uncoated (SBB, UZ) Multiply construction, Inverform

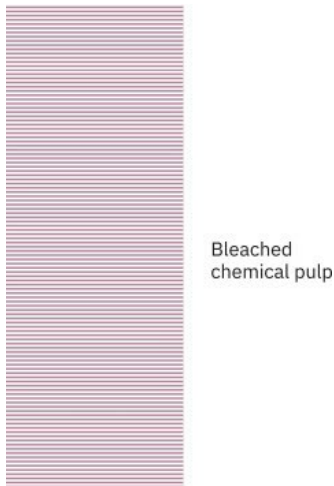

SBB is made exclusively from bleached chemical pulp.

# Abbreviations/keys

According to DIN 19303

GZ	Coated SBB	SBB	Solid Bleached Board
AZ	Cast Coated SBB	FBB	Folding Box Board
GC1	Coated FBB, white back	SUB	Solid Unbleached Board
GC2	Coated FBB, cream back	WLC	White Lined Chipboard
GN	Coated SUB, white or brown back	G	Coated
GT	Coated WLC, cream or white back	U	Uncoated
GD1	Coated WLC, grey back (spec.volume <1.45 cm <sup>3</sup> /g)	A	Cast coated
GD2	Coated WLC, grey back (spec.volume 1.3 to 1.45 cm <sup>3</sup> /g)	Z	Bleached virgin chemical pulp
GD3	Coated WLC, grey back (spec.volume <1.3 cm <sup>3</sup> /g)	C	Virgin mechanical pulp
UZ	Uncoated SBB	N	Unbleached virgin chemical pulp
UC1	Uncoated FBB, white back	T	Recycled with white or cream back
UC2	Uncoated FBB, cream back	D	Recycled with grey back
UT	Uncoated WLC, cream or white back		
UD	Uncoated WLC, grey back		

# Test methods

## General

This section contains an alphabetical list of the tests by which paperboard is evaluated during manufacture.

The list is divided into two parts:

- Paperboard property tests
- Extrusion/lamination property tests

These test methods evaluate the board properties, which influence the appearance and performance. Important test values (technical data) for the individual board products are quoted on the board data sheets that can be found at [iggesund.com/products](http://iggesund.com/products). The Paperboard Manual deals in further detail with the board properties in terms of appearance and performance, and how they influence the printing, converting and use of the board.

## Paperboard property tests

All properties are measured in a test climate of 23°C/50% RH at the mills. Board performance properties are measured on samples taken from the board production.

### Bending

Bending stiffness, bending resistance and bending moment, see Stiffness.

### Brightness

See Optical properties.

### Caliper

See Thickness.

### Cobb test

See Water absorption.

### Colour

See Optical properties.

### Gloss

The gloss of the paperboard surface is measured in accordance with ISO 8254-1<sup>1)</sup>. The gloss is expressed in % units. The surface of the board is illuminated at an angle of 75° and the reflection from the surface is recorded by a photoelectric cell.

Within Holmen Iggesund a surface having a measured value < 40% board gloss is regarded as matt. A medium gloss board is in the range of ≥ 40% to < 70%, and a high gloss board has a value of ≥ 70%.

<sup>1)</sup> ISO = International Organization for Standardization.

### Grammage

The grammage of the paperboard is assessed in accordance with ISO 536<sup>1)</sup>. Grammage expresses weight per unit area and is measured in g/m<sup>2</sup>.

<sup>1)</sup> ISO = International Organization for Standardization.

## Ink absorption

Ink absorption is measured using an internal test method. The ink absorption is expressed in % units. A specific ink is applied to the paperboard surface. The amount of ink absorbed in a given time is assessed by % reflectance compared with the unprinted surface.

## Interlayer strength

See Ply bond.

## Moisture content

The absolute moisture content is measured in accordance with ISO 287<sup>1)</sup>. It is expressed in % of the paperboard weight. The moisture content of the board is measured continuously on the board machine and recorded.

<sup>1)</sup> ISO = International Organization for Standardization.

## Opacity

The opacity of the paperboard is assessed in accordance with ISO 2471<sup>1)</sup>. The measuring principle is based on comparison of reflectance for a single paperboard sheet over a black background compared to an opaque pack of paperboard samples. Opacity is expressed in % units and readings close to 100 mean there is no show-through.

<sup>1)</sup> ISO = International Organization for Standardization.

## Optical properties

The term whiteness is often used as a comprehensive expression for some of the optical properties of the surface of paperboard, although whiteness is also a specific value that is measured today. The properties quoted here are CIE-whiteness, Brightness and Colour. Where paperboards include fluorescent whitening agents or FWAs (sometimes referred to as optical brightening agents or OBAs) measurements are made using an illuminant that contains a controlled element of ultra violet (UV) light. All values are measured both at Iggesund Mill and Workington Mill using Datacolor Elrepho instruments.

### Optical properties, CIE-whiteness

CIE-whiteness ( $W$ ) is a comprehensive term used to express the visual impact of near white surfaces by means of a single value. This value, based on CIE (Commission Internationale de l'Eclairage) tristimulus values, describes perceived whiteness in outdoor UV-rich illumination. A large number of equations have been developed to calculate whiteness, but CIE-whiteness is perhaps the most commonly used. CIE-whiteness is measured in accordance with ISO 11475<sup>1)</sup>.

<sup>1)</sup> ISO = International Organization for Standardization.

### Optical properties, ISO Brightness

This is the diffuse blue reflectance factor measured at an effective wavelength of 457 nm. As the measurement is only carried out in the blue region of the spectrum, it is of limited usefulness. ISO Brightness is measured in accordance with ISO 2470-1<sup>1)</sup>.

<sup>1)</sup> ISO = International Organization for Standardization.

### Optical properties, Colour

To quantify the impression of colour to the human eye of a nearly white surface, the CIE colour space can be used. Three reflectance figures  $L^*$ ,  $a^*$  and  $b^*$  known as the CIELAB coordinates are measured using a standard light source. The coordinates  $a^*$  and  $b^*$  measure colour. Positive figures for  $a^*$  express redness, negative figures greenness, and positive figures for  $b^*$  express yellowness, negative figures blueness.  $L^*$  is a percentage which measures luminance on a scale where black is zero and pure white is usually 100%. Colour is measured in accordance with ISO 5631-2<sup>1)</sup>.

<sup>1)</sup> ISO = International Organization for Standardization.

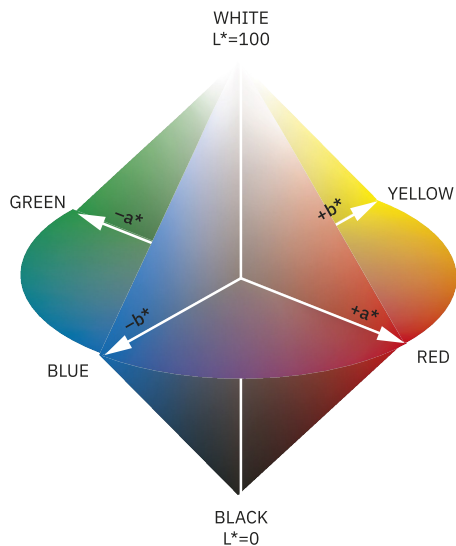

## Ply bond

The interply or interlayer strength of the paperboard is measured in accordance with ISO 16260<sup>1)</sup>. Ply bond is measured using a Scott Bond type tester and is expressed in J/m<sup>2</sup>.

<sup>1)</sup> ISO = International Organization for Standardization.

## Smoothness

See Surface roughness.

## Stiffness

A number of methods of measuring stiffness are recognised. Values for the following methods are quoted in this catalogue:

- Bending stiffness L & W 5°
- Bending resistance L & W 15°
- Bending moment Taber 15°

Since the stiffness is related to the orientation of fibres in the sheet during manufacture, two values are given: for the machine direction (MD) and the cross direction (CD).

## Stiffness, Bending resistance L & W 15°

Bending resistance is measured in accordance with ISO 2493-1<sup>1)</sup>. The bending resistance is expressed in mN.

<sup>1)</sup> ISO = International Organization for Standardization.

## Stiffness, Bending stiffness L & W 5°

Bending stiffness L & W 5° is measured in accordance with ISO 5628<sup>1)</sup>, DIN 53 121<sup>2)</sup>. The bending stiffness is expressed in mNm.

<sup>1)</sup> ISO = International Organization for Standardization. / <sup>2)</sup> DIN = Deutsche Industrie-Norm.

## Surface pH

Surface pH is measured on a water extract. It is expressed in pH units on a scale of 0 –14.

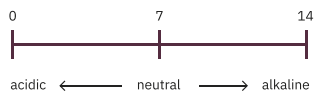

The pH scale.

## Surface roughness

Surface roughness is measured in accordance with ISO 8791-4<sup>1)</sup>, using the Parker Print Surf (PPS) roughness tester at 1000 kPa using a soft backing (S10). The surface roughness is expressed in  $\mu\text{m}$ . Lower results indicate smoother surfaces. Uncoated surfaces are measured using the Bendtsen method and the roughness is expressed in ml/min. Lower results indicate smoother surfaces.

<sup>1)</sup> ISO = International Organization for Standardization.

## Surface strength

The surface strength is measured in accordance with ISO 3783<sup>1)</sup>. The strength is expressed in m/s. This test evaluates the ability of the surface to withstand picking and blistering and is carried out using an IGT Printability Tester using a medium viscosity oil. Where strength is expressed in N/m the following correlation applies.

<sup>1)</sup> ISO = International Organization for Standardization.

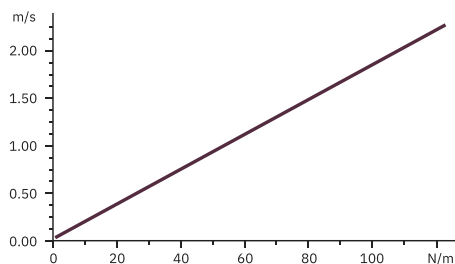

Relation between the unit of measurement for IGT-values.

## Surface water absorption

See Water absorption.

## Taint and odour

Taint and odour are assessed by members of trained panels who assign numerical ratings and record their impressions of tainting flavours or volatile smells experienced. Our paperboard products are tested by the Robinson taint test EN-1230-2.

GC (Gas Chromatographic) and Mass Spectrometer methods are used for assessing and identifying paperboard components and those arising from printing and conversion processes.

## Tearing resistance

The measured force required to tear a paperboard sheet is given for machine direction (MD) and cross direction (CD) respectively. Tearing resistance is measured in accordance with ISO 18522<sup>1)</sup> (Iggesund) and ISO 1974<sup>1)</sup> (Workington) and is expressed in mN.

<sup>1)</sup> ISO = International Organization for Standardization.

## Tensile strength

The tensile strength is the force required to rupture a strip of paperboard. Values are given for machine

direction (MD) and cross direction (CD) respectively. The tensile strength is measured in accordance with ISO 18522<sup>1)</sup> and is expressed in kN/m.

<sup>1)</sup> ISO = International Organization for Standardization.

## Thickness

The paperboard thickness is measured in accordance with ISO 534<sup>1)</sup>. The thickness is expressed in  $\mu\text{m}$ . Caliper (pts) is also recorded for reference on specification sheets, where pts are inches/1000.

<sup>1)</sup> ISO = International Organization for Standardization.

## Water absorption, Cobb test

The surface water absorption is measured using the Cobb test in accordance with ISO 535<sup>1)</sup>. The water absorption is expressed in  $\text{g}/\text{m}^2$ .

<sup>1)</sup> ISO = International Organization for Standardization.

## Water absorption, Wick test

Water absorption at the paperboard edge is measured using a Wick test. The paperboard surface is sealed with waterproof tape on both sides. The sample is weighed, placed in water at 80°C for 20 minutes and reweighed. The amount of water absorbed by wicking is expressed in  $\text{kg}/\text{m}^2$ .

## Whiteness

See Optical properties.

## Wick test

See Water absorption.

# Extrusion/lamination property tests

## Adhesion

See Surface strength.

## Grammage

Coat weight is measured continuously along and across the board web. It is expressed in  $\text{g/m}^2$  and can be used for calculating the coating thickness.

## Pinholes

Pinholes are microscopic holes that might appear in the plastic film during the coating process. These are very small; they are not visible to the human eye. A limited number of pinholes are of no importance in most cases. Pinholes are determined by exposing the plastic coating to dyed alcohol for a certain period of time and counting the number of coloured specks. The presence of pinholes is expressed in number/ $\text{m}^2$ .

## Surface roughness

Surface roughness is measured using the Parker Print Surf Roughness Tester. The surface roughness is expressed in  $\mu\text{m}$ . Lower results indicate smoother surfaces.

## Surface tension

See Wettability.

## Surface strength

Plastic adhesion (surface strength) is a dimensionless property defining the relation between adhesive and cohesive strength in the board surface. The internal method involves pulling a strip off the coating of the board and determining the degree of failure in the interlayer.

## Wettability

The wettability of a surface determines whether a printing ink or a glue will stay on and adhere to a surface. It is measured as the surface tension of a standard liquid that just wets the plastic surface. Surface tension is expressed in dynes/cm. The surface tension of a plastic surface is usually too low for printing or gluing. The surface is therefore corona treated to improve the wettability.

# Product and use

## Product performance

Demands for promotion and protection define the performance characteristics of paperboard, as do the requirements during conversion and distribution. The overall demand for minimum use, resource efficiency, competitive products and efficient systems requires paperboard with high performance combined with fitness for use. Holmen products are developed to provide high performance for specific uses. In marketing, sales and technical service, fitness for use and performance requirements are matched to ensure efficient solutions in every case. More information is available in the [Paperboard Manual \(https://www.iggesund.com/insights/paperboard-know-how/paperboard-manual/paperboard-manual-publication/\)](https://www.iggesund.com/insights/paperboard-know-how/paperboard-manual/paperboard-manual-publication/).

## Standard product specification and traceability

All products are manufactured to meet the specifications as described at [iggesund.com/products](https://www.iggesund.com/products). Review of the specifications is documented and performed according to the procedures in the Quality Management Systems within Holmen.

The correct application of specification tolerances provides the printer, converter and ultimately the end user with the assurance that the paperboard supplied has been produced under carefully controlled conditions to meet market quality requirements. In the manufacture of its products, Holmen continuously strives to minimise deviations from specified target values. To meet our customers' demands for quality and consistency, we also specify upper and lower tolerances as appropriate. In the control of product quality, Holmen uses online as well as laboratory measurements to monitor according to documented procedures.

## Our guarantee

Holmen guarantees that the material our customers receive has been assessed by sampling using both online and laboratory techniques. Quality parameters and all sample measurements are based on samples taken from board production and have been found to be within the published and agreed tolerances as detailed in the current edition of the Paperboard Product Catalogue that can be found at [iggesund.com](https://www.iggesund.com) or approved amendment. We strongly recommend fully testing the product at every stage through the supply chain before going into full production. Your local Technical Service contact should be involved to achieve maximum product performance.

In situations where there are doubts about the performance of the paperboard or compliance with the specifications, tools are available to trace information related to the product and/or order. The Holmen Iggesund document Terms and Conditions of Trade 2022 constitutes the whole agreement between Holmen (Seller) and the Buyer and here it is stressed that in the case of a claim, the clear identification of the goods is a requirement. This is to enable above mentioned traceability to relevant product data. For the customer, the key to traceable information is the order number and package number as this information is the link to all product data and laboratory and machine records. Retrievable data are stored for a minimum of two years. Procedures and systems are in place to achieve the necessary traceability back to Holmen's suppliers.

## Taint and odour neutrality

To ensure that our paperboard meets the demands for taint and odour neutrality, we regularly monitor production using organoleptic test procedures through an accredited laboratory. We guarantee that our baseboard products Invercote, Incada and Inverform register Robinson taint values according to EN1230-2 that are below the detection limit. As an integral part of our product quality assurance policy, Holmen accepts responsibility for taint and odour problems proven to have been caused by our products.

# Product purity and hygiene

For end uses such as food, confectionery and pharmaceuticals, purity and hygiene are of critical importance. In order to maintain correct product performance Holmen only uses approved raw materials and additives, and carries out the production process according to manufacturing practices that incorporate the use of risk assessment methods. Every chemical additive is assessed according to occupational health and safety, environmental impact and product safety before it is allowed to be used.

## Product labelling

Presently there are several labelling schemes on the market that claim to communicate representative facts about product performance and environmental acceptability (eco-labels), such as EU Ecolabel and Cradle to Cradle. A selected number of our grades fulfil the requirements of Nordic Ecolabel for printing companies.

## Environmental Declaration

The international development of Environmental Product Declarations is promising, but until these are developed and become an accepted standard, reference is made to the Holmen declarations which are available upon request or can be downloaded from [iggesund.com/certificates](https://www.iggesund.com/certificates) (<https://www.iggesund.com/sustainability/our-production/certificates-and-awards/>).

## Product safety and liability

The essence of packaging is to ensure the quality, hygiene and safety of the packed product. To ensure these, a number of national and international rules and regulations must be met. In addition, company and product-specific measures are usually added. The final goal is to secure fitness for the intended use. It is important to protect the packed product against contamination from various external factors. Holmen products are therefore, made only from high quality primary fibres and functional additives which ensure safety, hygiene and good organoleptic properties of the products. Where necessary, additional barrier materials can be applied to ensure that the quality of a packed product can be safely maintained.

In many countries, consumer safety is protected by product liability legislation with far-reaching consequences for the supply chain. In the event of damage, all players along the supply chain are responsible to the consumer (joint and separate responsibility). The only exception is when you can prove, for your own area of responsibility, the fulfilment of the relevant requirements. A key consequence is thus to ensure the complete understanding and verification between supplier and customer of all the relevant aspects.

## Declaration of compliance

Holmen will, upon request, issue a product declaration to verify the fitness and safety of a product for the intended use. In order to create the document, a customer must provide the specific conditions of the intended use of the Holmen product. Communication along the supply chain is of decisive importance for the result of the correct and appropriate compliance work in relation to the actual end-use application. The declarations of compliance are issued after having carefully checked that the intended use of a specific paperboard product, under specified conditions of use, will not endanger the quality and safety of the packed product. The specific statements in the declaration are integral parts of the Holmen Management System. The information provided is valid for two years.

# Rules, regulations and good manufacturing practice

Over the years, many countries have developed regulations to control the safety of the packaging materials in order to prevent cross-contamination between the packed product and the packaging. The best known and currently most widely recognised regulations are summarised in the table below. In the absence of harmonised European legislation for paper and board intended to be used in contact with food, Holmen ensures that its paperboard products fulfil the relevant requirements listed.

## Food safety, rules and regulations

All Holmen products will, subject to application/intended use, fulfil the requirements listed below:

Regulations	Abbreviation/Code	Country
Regulation No 1935/2004 on materials and articles intended to come into contact with food	Framework Regulation 1935/2004	EU
BfR recommendations XXXVI on paper and board for food contact	BfR XXXIV	Germany
EU Directive 94/62/EC on packaging and packaging waste	EU Packaging and Packaging Waste Directive	EU
Regulation No 1907/2006 concerning the Registration, Evaluation, Authorisation and Restriction of Chemicals	REACH	EU
Commission Regulation (EC) No 2023/2006 on good manufacturing practice for materials and articles intended to come into contact with food	GMP	EU
EU Directive 2009/48/EC on the safety of toys	Safety of toys	EU
Requirements for the Safety of Toys – Part 3: Migration of certain elements	EN 71 Part 3	Worldwide
Requirements for the Safety of Toys – Part 9: Organic chemical compounds	EN 71 Part 9	Worldwide
Legislation from the Coalition of North Eastern Governors regarding the content of mercury lead, cadmium and hexavalent chromium in packaging and packaging components	CONEG	Worldwide
Food and Drugs Administration Title 21 of Code of Federal Regulations regarding Food and Drugs	FDA 21 CFR	US
Regulation (EU) No 995/2010 laying down the obligations of operators who place timber and timber products on the market	Timber Regulation	EU

For certain geographical areas or specific end uses, certain requirements must be met or enhanced barrier functions could be needed. For instance, a barrier between the board and the packed foodstuffs is recommended when the board is used for fatty or aqueous packaging applications. Holmen will ensure that the appropriate product/barrier combinations fulfil the requirements for the defined intended use. Barrier functions are generally achieved by plastic coating.

The plastic itself, in all plastic coatings, meets the requirements of the Commission Regulation (EU) 10/2011 and its subsequent amendments. For plastic coating/lamination, only raw materials which are suitable for the specific application are used. Analysis of total migration tests are regularly made to verify compliance.

## Good manufacturing practise

The Commission Regulation (EC) No 2023/2006 on good manufacturing practice for materials and articles intended to come into contact with food lays down rules on good manufacturing practice. The main requirement in this regulation is that we as a manufacturer shall operate an effective food safety management system in our manufacturing process.

Holmen Iggesund has Food Safety System Certification (FSSC 22000 v5.1) for Food Packaging and

Packaging Material (Category: I) in place. The certification scheme for food safety management systems consists of the following elements: ISO 22000:2018, ISO/TS 22002-4:2013 and additional FSSC 22000 requirements (version 5.1). The certificate is applicable for the scope of board production, finishing, coating/lamination to be used in the food industry.

## Used products - waste management and producer responsibility

The EU Directive on Packaging and Packaging Waste, 94/62/EC and subsequent amendments, defines common requirements on packaging and packaging waste within the EU. However, the Directive's formal implementation and interpretation and the practical methods introduced by the member countries vary widely. As a consequence, the requirements and methods differ between countries.

In some countries, producer responsibility has been introduced and has led to industry-owned organisations which manage used packaging. In other countries, there are community or nationwide schemes more or less controlled by the authorities. The result is systems with very different approaches to how packaging is taken care of and the costs involved. Each country has its own systems and rules. Waste generated during the manufacture of Holmen's products is managed and reported according to the permits given by the local authorities.

### The EU Directive on Packaging and Packaging Waste (94/62/EC)

The EU Directive (94/62/EC) is aimed at minimising the environmental impact of packaging and packaging waste. It places an obligation on prevention by source reduction, re-use or recovery of used packaging and minimisation of heavy metal contamination. The EU Commission gave the European Standards Organisation, CEN, a mandate to develop standards to be used as EU harmonised standards to ensure the fulfilment of the essential requirements. During 2004 CEN adopted and published the following standards: EN 13427:2004, EN 13428:2004, EN 13429:2004, EN 13430:2004 and EN 13431:2004. EN 13432:2000 was already published.

### In general the following is valid for Holmen products:

Holmen will act to meet all the relevant requirements of the directive, and will use the previously mentioned CEN packaging standards to assess and document compliance with the essential requirements. EN 13427:2004 is called "the umbrella standard" which guides users through the texts, indicating which standards are applicable to each type of packaging. EN 13428:2004 consists of two parts of which the first covers "prevention by source reduction", and the second "qualitative prevention by minimising the presence of noxious and hazardous substances in the packaging material".

In the areas of product development, marketing, sales and technical service, fitness for intended use is given priority to ensure that the main purposes and functions are fulfilled with a minimum of material. In the area of transport packaging the demand for prevention by source reduction is applicable and fulfilled by supplier requirements as defined in the standard.

All products meet the requirements regarding determination and minimisation of noxious and hazardous substances. EN 13429:2004 regarding reusable packaging is not applicable for our products. Product design and composition is such that material recycling (EN 13430:2004) or energy recovery (EN 13431:2004) can be done without limitation. Our baseboards are intrinsically biodegradable. For the quantification regarding composting, tests should be made on the final packaging after the converting process (EN 13432:2000).

# Typical applications for our paperboard

The Holmen products can be extrusion coated with plastics as barriers and glue or extrusion laminated with board, foil or film to achieve special functions. Below you will find examples of various applications, what barriers they require, and what board grades are suitable. To read more about the plastic coating or laminate properties, go to [lggesund.com/products](http://lggesund.com/products).

For a description of the baseboard, please see the respective product specification. Some products in the overview are not presented in the catalogue but are available upon request and some applications are not listed. Please contact your local Holmen Board and Paper representative for information and recommendations.

Typical product application	Type of board/grade	Type of plastic coating/ laminate
Vegetables (packed pre-frozen) Fish and other seafood (packed pre-frozen) Meat products (packed pre-frozen) Cups and containers Ice cream and frozen desserts Sugar confectionery Chocolate	Invercote GP Incada Exel Inverform	1-side PE
Fish and other seafood (packed wet) Vegetables (packed wet) Cups and containers Ice cream and frozen desserts	Invercote GP Incada Exel Inverform	2-sides PE
Lids and trays for reheating of food	Invercote GP Incada Exel Inverform	1-side PP 2-sides PP
Lids for trays for cooking and reheating of food Trays for cooking and reheating of food Trays for baking (pressed or creased cartons) Confectionery	Invercote GP Inverform	1-side PET
Confectionery Tobacco Biscuits and other food Cake mixes Cereals Ice cream	Invercote G Incada Exel	AlubARRIER
Wine and spirits Tobacco Perfume and cosmetics Hair care and toiletries Pharmaceuticals Brochures Confectionery	Invercote G Invercote Creato Invercote Albato Incada Silk Incada Exel	Metalprint

## Product range

The Holmen product range is very extensive and includes solid bleached boards from 180– 400 g/m<sup>2</sup> and folding box boards from 200–350 g/m<sup>2</sup> as well as versions where sheets are glued together or extrusion laminated with foil or film. Below you will find examples of the typical end uses and the grammage/thickness range for the respective products. For further information, please contact your local Holmen Board and Paper contact or visit [iggesund.com \(https://www.iggesund.com/\)](https://www.iggesund.com).

Typical application	Type of board/ Grade	Grammage (g/m <sup>2</sup> )	Thickness (µm)
Solid Bleached Board (SBB, GZ)			
Perfumes, Cosmetics, Chocolates, Pharmaceuticals, Wines and spirits, Book and CD-covers, Cards, Brochures, Advertising material	Invercote G	180-380	205-505
Brochure and catalogue covers, Folders, Tags, Point of sales, CD-covers, Cards, Tobacco	Invercote Creato	220-400	230-485
Perfumes, Cosmetics, Chocolates, Wines and spirits, Advertising material, Covers, Cards, Media, Tobacco	Invercote Albato	250-350	242-285
Tobacco	Invercote Lenato	220-260	275-350
Tobacco	Invercote T	220-280	275-365
Folding Box Board (FBB, GC1)			
Cosmetics, Chocolates, Medical and health care, Covers, Cards, Media	Incada Silk	220-350	325-590
Tobacco	Incada Silk C	220-340	330-350
Folding Box Board (FBB, GC2)			
Frozen and chilled food, Confectionery, Wines and spirits, Beverages, Biscuits and other foods, Pharma and health care, Microwaveable products	Incada Exel	200-350	310-640
Board Laminates			
Advertising material, Games, Wines and spirits, CD-holders, Covers, Point of sales, Brochures, Tags, Chocolates, Glassware, Perfumes and cosmetics	Invercote Duo	450-770	520-1010
Brochures, Tags, Advertising material, Games, CD-holders, Wines and spirits, Electronic goods	Incada Duo	410-995	610-1740
Foil and Film Laminates			
Tobacco, Wine and spirits, Perfume and cosmetics, Hair care and toiletries, Pharmaceuticals, Brochures, Confectionery	Metalprint	Depending on choice of baseboard grade	
Confectionery, Tobacco, Biscuits and other foods, Ice cream	AlubARRIER	Depending on choice of baseboard grade	
Formable Solid Bleached Board			
Lids for trays for cooking and reheating food, Trays for cooking and reheating of food, Trays for baking (pressed or creased cartons), Trays for chilled food, Cups and containers	Inverform	290-380	400-530

## Online version

Access the online version of this spec sheet on: [iggesund.com/gti](https://iggesund.com/gti)



