

SIAT

MAILLIS

F105 / PS50-TB

Semi-Automatic Case Erectors

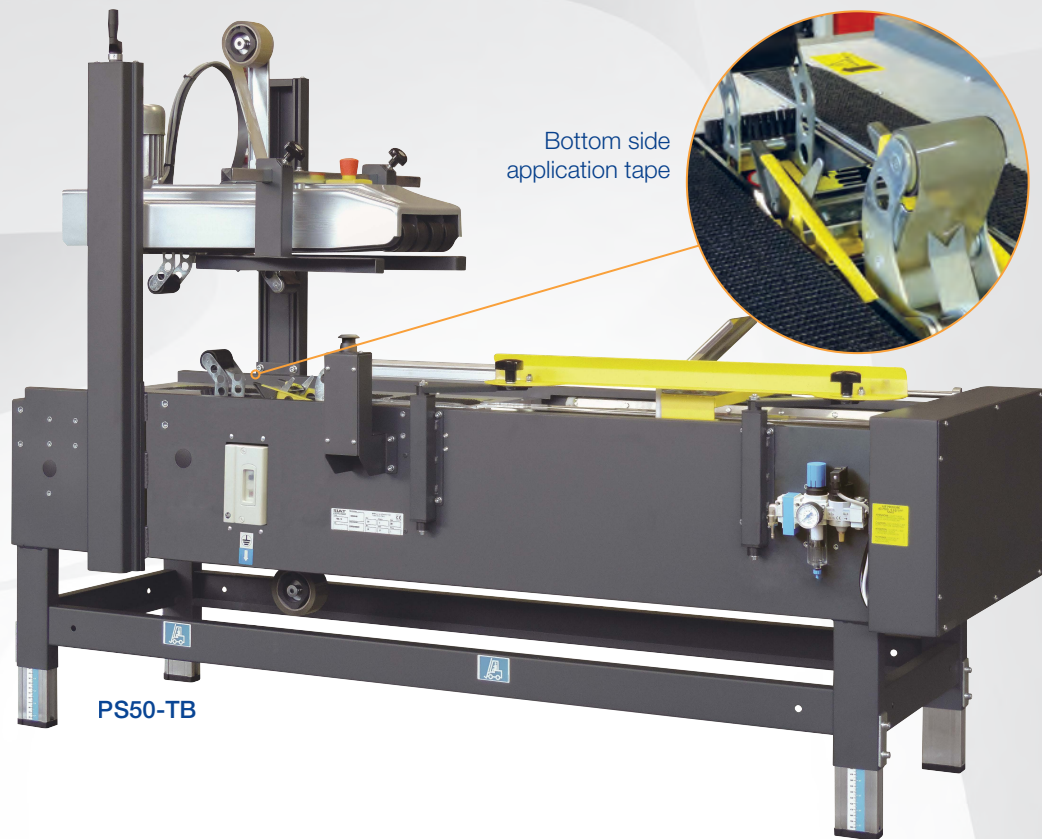

Bottom side application tape

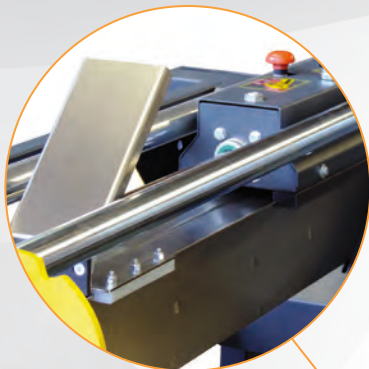

Detail of the new pusher



F105



Detail of the new pneumatic unit

CE

for more details:



F105



PS50-TB

The case former folds the bottom flaps of boxes entered into machine by an operator, allowing a time saving of 50%.

The F105 case former machine automatically folds the bottom flaps of the box manually entered by an operator. The box with the bottom flaps folded remains in vertical position for filling operation. Subsequently it could be pushed through a pneumatic cylinder in a "fixed format" case sealer machine for sealing with adhesive tape.



other languages: www.siat.com



> F105

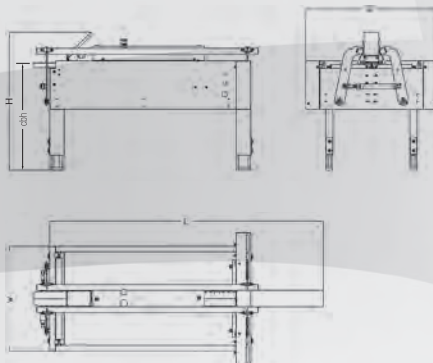

> PS50-TB

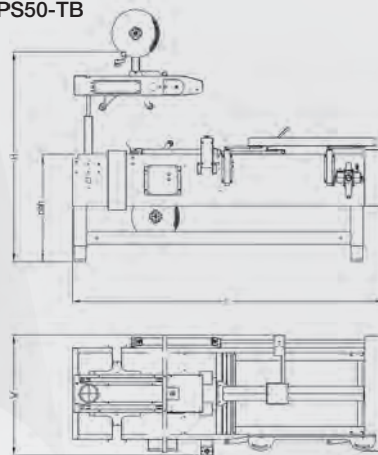

> Machine dimensions

Dimensioni macchina
Machinemessungen
Dimensions machine
Dimensiones de la máquina

Size / Weight packaging			LxWxH
> F105	110	125	148x88x95
> PS50	225	250	202x83x126

> F105

	Min.	Max
L	1260	1660
W	570	933
H	695	855
cbh	525	675
AS 77	775	935
AS 80	895	1055

> PS50-TB

	Min.	Max
L	1952	-
W	753	-
H	1305	1505
cbh	585	735
AS 77	685	885
AS 80	785	985

> Taping units

Unità nastranti
Verschliesseinheiten
Unité enrubanouse
Unidades de precinto

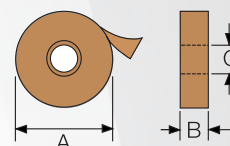

> Box dimensions

Dimensioni delle scatole
Kartonabmessungen
Dimensions des boîtes
Dimensiones de las cajas

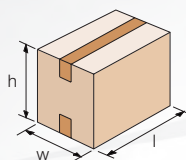

> F105

	Min.	Max
l	200	600
w	90	500
h	90	500

> PS50-TB

	K11R	
	Min.	Max
l	150	600
w	150	500
h	100	500

	K11R
	mm
A	410 Max
B	50
C	76

> Production capacity

Capacità di produzione
Produktionskapazität
Capacité de production
Capacidad de producción

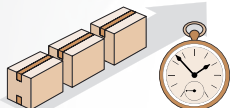

> F105

	Bph
Max pcs.*	600

> PS50-TB

	Bph
Max pcs.*	600

* Always based on shorter manageable box

> Air consumption

Consumo aria
Druckluftverbrauch
Consommation air comprimé
Consumo de arie

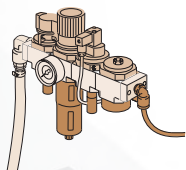

> F105 / PS50-TB

	NL.
Cycle	14,2

from 5,5 bar to 7 bar

> PS50-TB

380/400V - 50Hz - 3F	
440V - 60Hz - 3F	
Amps	1,08
Power kW	0,26
Phase	3Ph + N + PE

> Standard voltage

Voltaggio standard
Standardspannung
Tension standard
Voltaje estándar

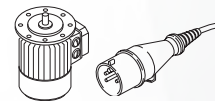

> Optionals

Accessori
Zubehör
Accessories
Accesorios

> AS80

Higher legs
Set gambe più alte
Höhere Stützen
Pieds plus hauts
Patas más altas



> AS77

Casters
Set ruote
Rädchen
Roulettes
Ruedas

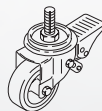

> RG

Roller conveyor
Piani a rulli
Rollenbahnen
Plans à rouleaux
Rodillos libres



> GTL - GTR

Extendable conveyor
Rulliera estensibile
Ausziehbare rollenbahnen
Convoyeur extensible
Rodillos extensibles

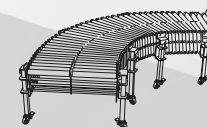

SIAT SIAT S.p.A.

Via Puecher, 22 - 22078 Turate (CO) Italy
Tel +39.02.964951 • Fax +39.02.9689727
www.siat.com • siat@siat.com

MAILLIS